

---

## DIGITAL AUDIO PROCESSOR WITH ANALOG INTERFACE

---

### FEATURES

- Digital Audio Processor
- Fully Programmable With Graphical, Drag-and-Drop **PurePath Studio™** Software Development Environment
- 135-MHz Operation
- 48-Bit Data Path With 76-Bit Accumulator
- Hardware Single-Cycle Multiplier (28 × 48)
- Five Simultaneous Operations Per Clock Cycle
- Usable 768 Words Data RAM (48 Bit), Usable 1K Coefficient RAM (28 Bit)
- Usable 2.5K Program RAM
- 360 ms at 48 kHz, 17K Words 24-Bit Delay Memory
- Slave Mode  $F_s$  is 44.1 kHz and 48 kHz
- Master Mode  $F_s$  is 48 kHz
- Analog Audio Input/Output
  - 10:1 Stereo Analog Input MUX
  - Stereo Analog Pass-Through Channel
  - Stereo, Single-Ended ADC (93 dB DNR Typical)
  - Six Single-Ended DACs (97 dB DNR Typical)
  - Stereo Headphone Amplifier, 24-mW Power Output into 16  $\Omega$ , 100 pF
- Digital Audio Input/Output
  - Three Synchronous Serial Audio Inputs (Six Channels)
  - Two Synchronous Serial Audio Outputs (Four Channels)
  - Input and Output Data Formats: 16-, 20-, or 24-Bit Data Left, Right, and I<sup>2</sup>S
  - SPDIF Transmitter
- System Control Processor
  - Embedded 8051 WARP Microprocessor
  - Programmable Using Standard 8051 C Compilers
  - Four Programmable GPIO Pins
- General Features
  - Two I<sup>2</sup>C Ports for Slave or Master Download
  - Single 3.3-V Power Supply
  - Integrated Regulators

### APPLICATIONS

- Flat-Screen TVs
- MP3 Players/Music Phone Docks
- Speaker Bars
- Mini/Micro Component Systems
- Automotive Head Units
- Musical Instruments



Please be aware that an important notice concerning availability, standard warranty, and use in critical applications of Texas Instruments semiconductor products and disclaimers thereto appears at the end of this data sheet.

PurePath Studio, PurePath Studio, PowerPAD are trademarks of Texas Instruments.

**PZP PACKAGE  
(TOP VIEW)**

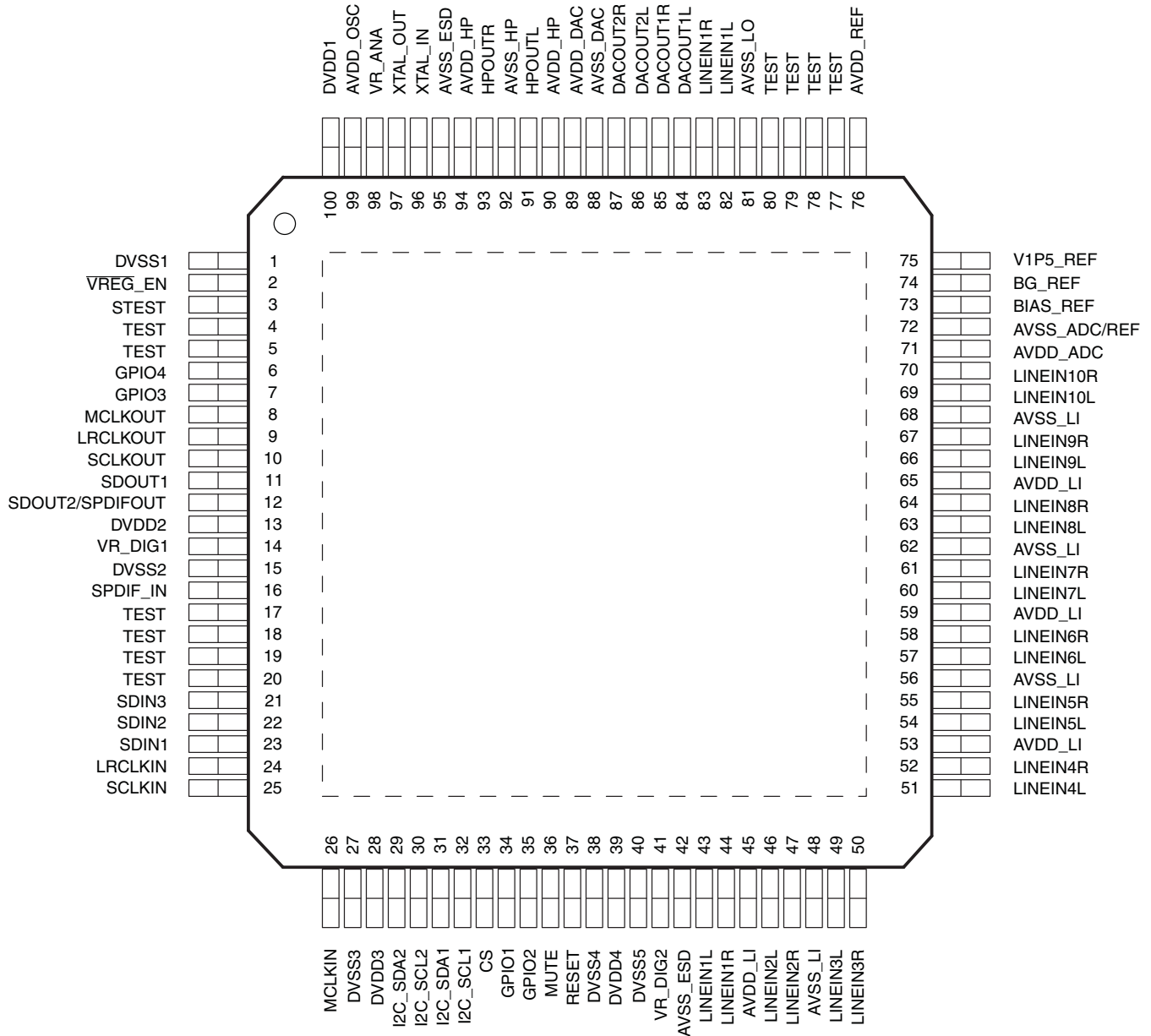

**ORDERING INFORMATION**

T <sub>A</sub>	PACKAGE <sup>(1)(2)</sup>		ORDERABLE PART NUMBER	TOP-SIDE MARKING
–40°C to 85°C	TQFP – PZP	Tape and reel	TAS3208IPZP	TAS3208IPZP
			TAS3208IPZPR	
–20°C to 70°C			TAS3208PZP	TAS3208PZP
			TAS3208PZPR	

(1) Package drawings, thermal data, and symbolization are available at [www.ti.com/packaging](http://www.ti.com/packaging).

(2) For the most current package and ordering information, see the Package Option Addendum at the end of this document, or see the TI website at [www.ti.com](http://www.ti.com).

**TERMINAL FUNCTIONS**

TERMINAL		I/O	TERMINATION <sup>(1)</sup>	DESCRIPTION
NO.	NAME			
1	DVSS1	P		Digital ground
2	VREG_EN	DI		Voltage regulator enable
3	STEST	DI	Pulldown	Test pin to reconfigure pins
4, 5, 17, 18, 19, 20	TEST	–	Pulldown	
6	GPIO4	DIO	Pulldown	General-purpose input/output 4
7	GPIO3	DIO	Pulldown	General-purpose input/output 3
8	MCLKOUT	DO		Master clock output
9	LRCLKOUT	DO		Left/right (frame) clock output
10	SCLKOUT	DO		Serial audio data clock output
11	SDOUT1	DO		Serial digital audio data output 1
12	SDOUT2/ SPDIF_OUT	DO		Serial digital audio data out 2/SPDIF output
13	DVDD2	P		3.3-V digital power
14	VR_DIG1	P		Pinout of internal regulator. A 4.7- $\mu$ F low-ESR capacitor should be connected between this pin and digital ground. This terminal must not be used to power external devices.
15	DVSS2	P		Digital ground
16	SPDIF_IN	DI		SPDIF input
21	SDIN3	DI		Serial digital audio data input 3
22	SDIN2	DI		Serial digital audio data input 2
23	SDIN1	DI		Serial digital audio data input 1
24	LRCLKIN	DI		Left/right (frame) clock input
25	SCLKIN	DI		Serial audio data clock input
26	MCLKIN	DI		Master clock input
27	DVSS3	P		Digital ground
28	DVDD3	P		3.3-V digital power master
29	I2C_SDA2	DIO		I <sup>2</sup> C serial data master
30	I2C_SCL2	DIO		I <sup>2</sup> C serial clock slave
31	I2C_SDA1	DIO		I <sup>2</sup> C serial data slave
32	I2C_SCL1	DIO		I <sup>2</sup> C serial clock
33	CS	DI		Chip select
34	GPIO1	DIO		General-purpose input/output 1
35	GPIO2	DIO		General-purpose input/output 2
36	MUTE	DI	Pullup	Mute device
37	RESET	DI	Pullup	Reset
38	DVSS4	P		Digital ground
39	DVDD4	P		3.3-V digital power
40	DVSS5	P		3.3-V digital power
41	VR_DIG2	P		Pinout of internal regulator. A 4.7- $\mu$ F low-ESR capacitor should be connected between this pin and digital ground. This terminal must not be used to power external devices.
42	AVSS_ESD	P		Analog ESD ground
43	LINEIN1L	AI		Left-channel analog input 1

(1) All pullups are 20- $\mu$ A weak pullups, and all pulldowns are 20- $\mu$ A weak pulldowns (166 k $\Omega$ ). The pullups and pulldowns are included to ensure proper input logic levels if the terminals are left unconnected (pullups at logic 1 input; pulldowns at logic 0 input). Devices that drive inputs with pullups must be able to sink 20  $\mu$ A while maintaining a logic 0 drive level. Devices that drive inputs with pulldowns must be able to source 20  $\mu$ A while maintaining a logic 1 drive level.

**TERMINAL FUNCTIONS (continued)**

TERMINAL		I/O	TERMINATION <sup>(1)</sup>	DESCRIPTION
NO.	NAME			
44	LINEIN1R	AI		Right-channel analog input 1
45, 53, 59, 65	AVDD_LI	P		3.3-V analog power
46	LINEIN2L	AI		Left-channel analog input 2
47	LINEIN2R	AI		Right-channel analog input 2
48, 56, 62, 68	AVSS_LI	P		Analog ground
49	LINEIN3L	AI		Left-channel analog input 3
50	LINEIN3R	AI		Right-channel analog input 3
51	LINEIN4L	AI		Left-channel analog input 4
52	LINEIN4R	AI		Right-channel analog input 4
54	LINEIN5L	AI		Left-channel analog input 5
55	LINEIN5R	AI		Right-channel analog input 5
57	LINEIN6L	AI		Left-channel analog input 6
58	LINEIN6R	AI		Right-channel analog input 6
60	LINEIN7L	AI		Left-channel analog input 7
61	LINEIN7R	AI		Right-channel analog input 7
63	LINEIN8L	AI		Left-channel analog input 8
64	LINEIN8R	AI		Right-channel analog input 8
66	LINEIN9L	AI		Left-channel analog input 9
67	LINEIN9R	AI		Right-channel analog input 9
69	LINEIN10L	AI		Left-channel analog input 10
70	LINEIN10R	AI		Right-channel analog input 10
71	AVDD_ADC	P		3.3-V analog power
72	AVSS_ADC/REF	P		Analog ground
73	BIAS_REF	AO		Pin should be tied to analog ground with 22 kΩ ± 1%.
74	BG_REF	AO		Band-gap output. Must be tied to ground with 1-μF low-ESR capacitor.
75	V1P5_REF	AO		Common-mode output. Must be tied to ground with 1-μF low-ESR capacitor.
76	AVDD_REF	P		3.3-V analog power
77, 78, 79, 80	TEST	–		
81	AVSS_LO	P		Analog ground
82	LINEOUT1L	AO		Left-channel analog output 1
83	LINEOUT1R	AO		Right-channel analog output 1
84	DACOUT1L	AO		Left-channel digital-to-analog converter output 1
85	DACOUT1R	AO		Right-channel digital-to-analog converter output 1
86	DACOUT2L	AO		Left-channel digital-to-analog converter output 2
87	DACOUT2R	AO		Right-channel digital-to-analog converter output 2
88	AVSS_DAC	P		Analog ground
89	AVDD_DAC	P		3.3-V analog power
90	AVDD_HP	P		3.3-V analog power
91	HPOUTL	AO		Left-channel headphone output
92	AVSS_HP	P		Analog ground
93	HPOUTR	AO		Right-channel headphone output
94	AVDD_HP	P		3.3-V analog power
95	AVSS_ESD	P		Analog ground
96	XTAL_IN	DI		External crystal input

**TERMINAL FUNCTIONS (continued)**

TERMINAL		I/O	TERMINATION <sup>(1)</sup>	DESCRIPTION
NO.	NAME			
97	XTAL_OUT	DO		External crystal output
98	VR_ANA	P		Pinout of internal regulator. A 4.7- $\mu$ F low-ESR capacitor should be connected between this pin and digital ground. This terminal must not be used to power external devices.
99	AVDD_OSC	P		3.3-V analog power
100	DVDD1	P		3.3-V digital power

**DESCRIPTION**

The TAS3208 is a highly-integrated audio system-on-chip (SOC) consisting of a fully-programmable 48-bit digital audio processor, 10:1 stereo analog input MUX, stereo ADC, six DACs, and other analog functionality. The TAS3208 is programmable with the graphical [PurePath Studio™](#) suite of DSP code development software. PurePath Studio is a highly intuitive, drag-and-drop development environment that minimizes software development effort while allowing the end user to utilize the power and flexibility of the TAS3208's digital audio processing core.

TAS3208 processing capability includes speaker equalization and cross over, volume/bass/treble control, signal mixing/MUXing/splitting, delay compensation, dynamic range compression, and many other basic audio functions. Audio functions such as matrix decoding, stereo widening, surround sound virtualization and psychoacoustic bass boost are also available with either third party or TI royalty-free algorithms.

The TAS3208 contains a custom-designed, fully-programmable 135-MHz, 48-bit digital audio processor. A 76-bit accumulator ensures that the high precision necessary for quality digital audio is maintained during arithmetic operations. A stereo, 93-dB DNR ADC and six 97-dB DNR DACs ensure that high-quality audio is maintained through the whole signal chain.

The TAS3208 is composed of seven functional blocks:

- Clock and serial data interface
- Analog input and output
- M8051 WARP controller, serial control interface, and device control
- Audio DSP – digital audio processing
- Power supply
- Internal references

[Figure 1](#) shows the functional structure of the TAS3208.

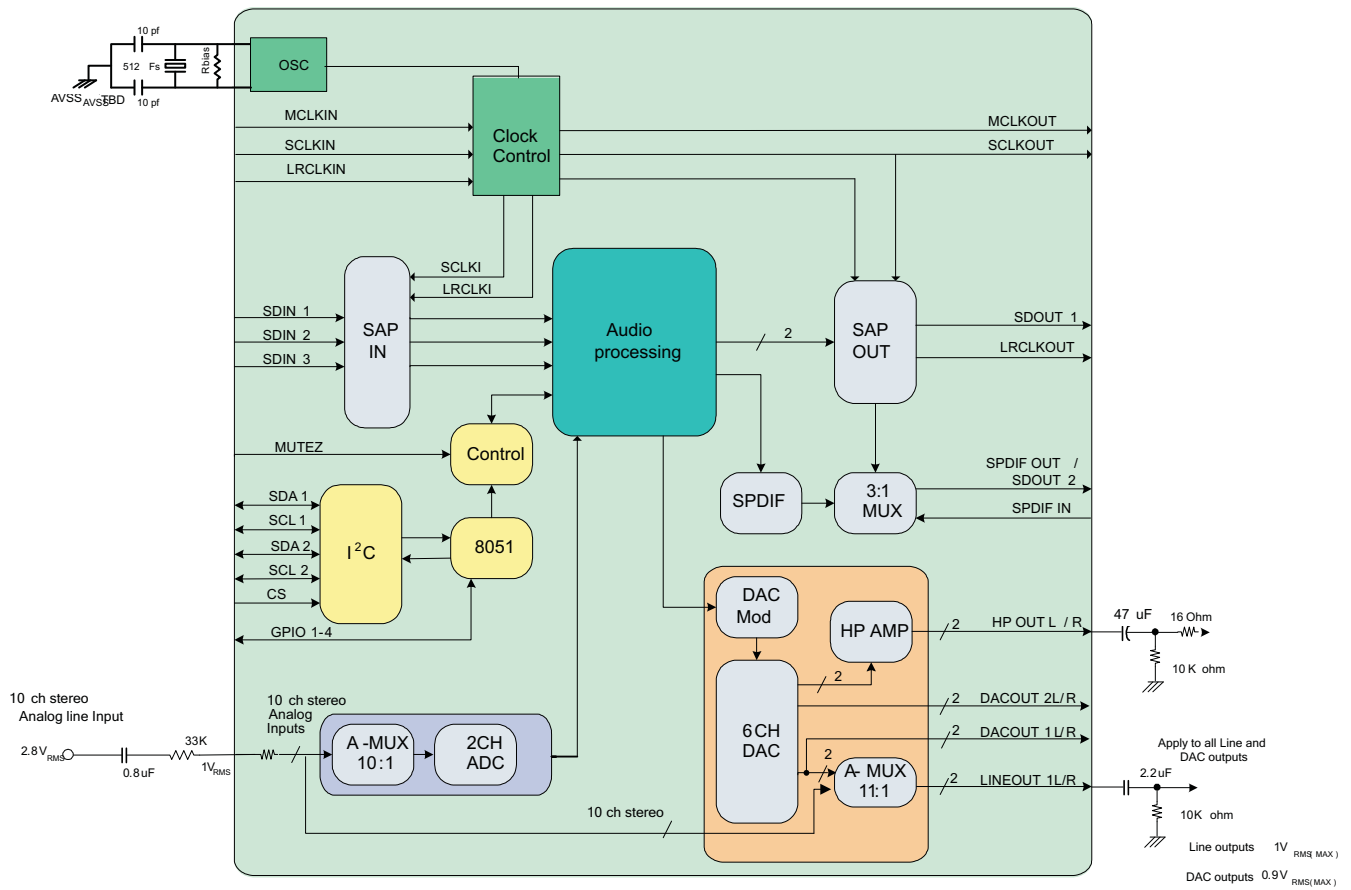

Figure 1. Block Diagram

The TAS3208 may be used with an external asynchronous sample rate converter (ASRC) to accommodate asynchronous serial inputs at different sampling rates (see [Figure 2](#)).

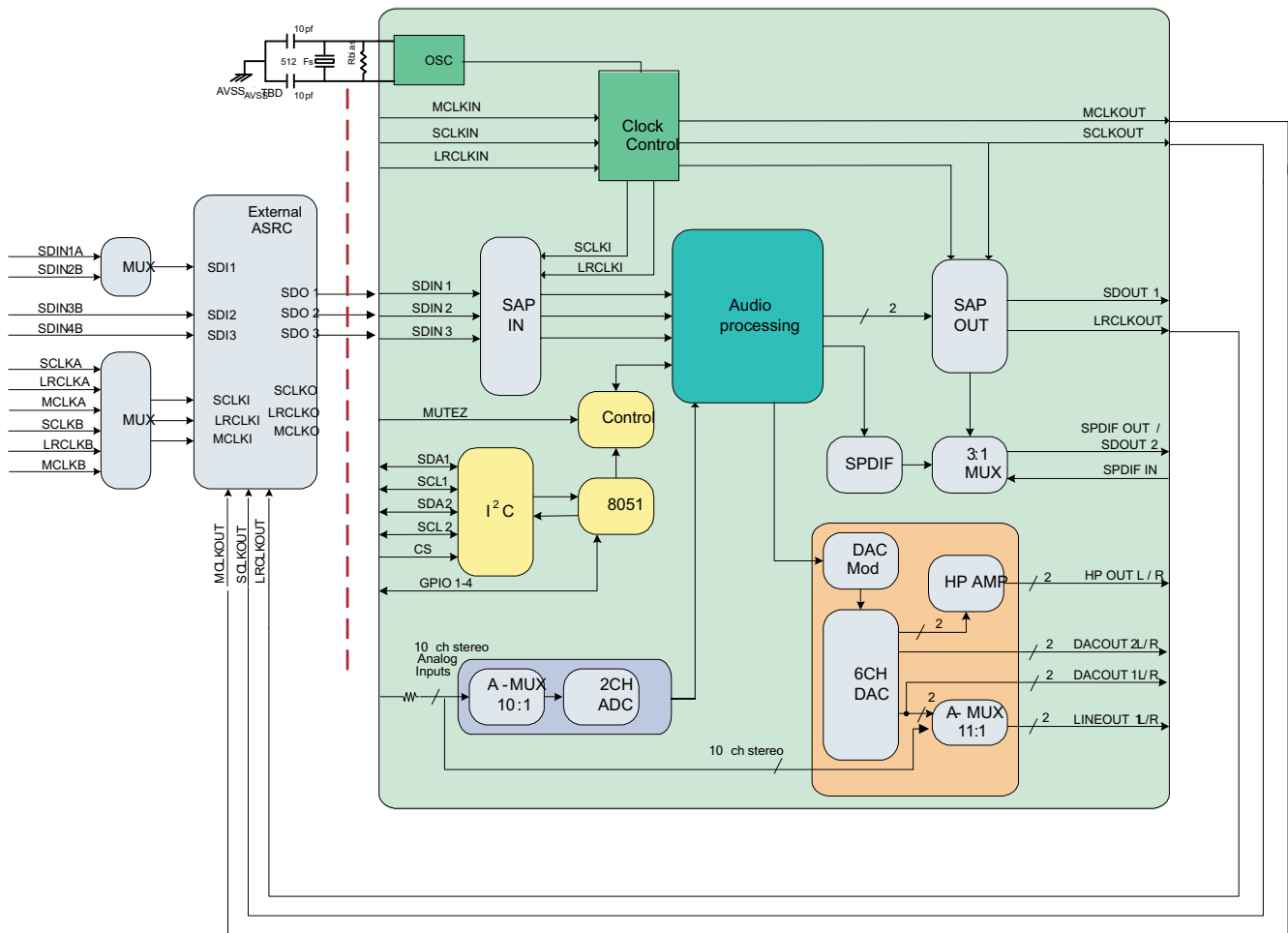

Figure 2. Interface to External ASRC

### Clocks

The TAS3208 can be configured as either the clock master or clock slave depending on the settings in the clock configuration register. By default, the TAS3208 is configured as the clock master. Figure 3 shows the block diagram of the TAS3208 clocks.

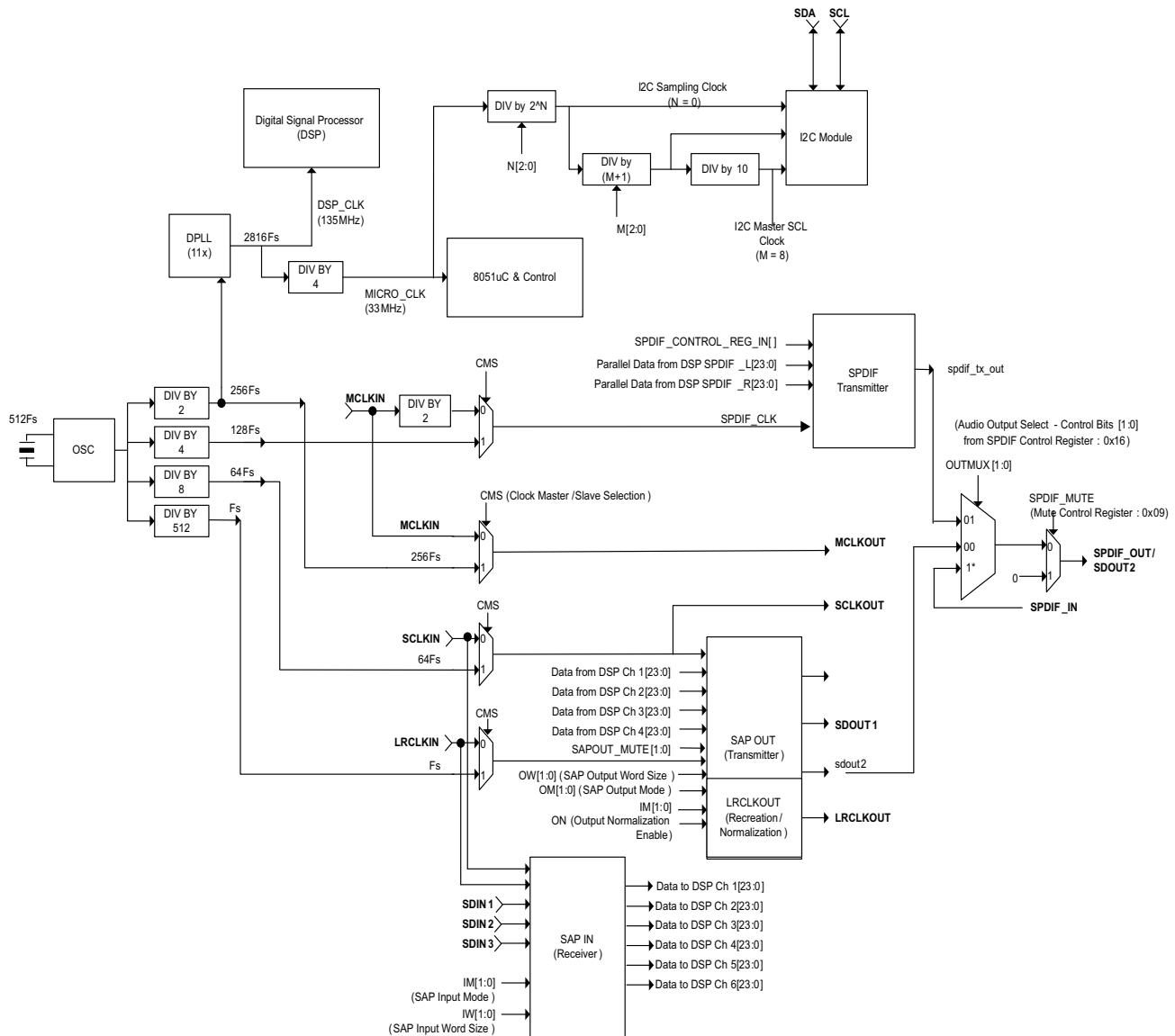

Figure 3. Clocking System

### Digital Audio Interface

The TAS3208 has three digital inputs that accept discrete I<sup>2</sup>S, discrete left-justified, and discrete right-justified PCM data.

The TAS3208 has two digital outputs that provide discrete I<sup>2</sup>S, discrete left-justified, and discrete right-justified PCM data. The second digital output can also be configured to provide SPDIF encoded PCM data.

The TAS3208 has a SPDIF input that is capable of routing an SPDIF-encoded signal through the device. This input is not processed by the digital audio processor (DAP). The clocking system for the device is shown in Figure 4.



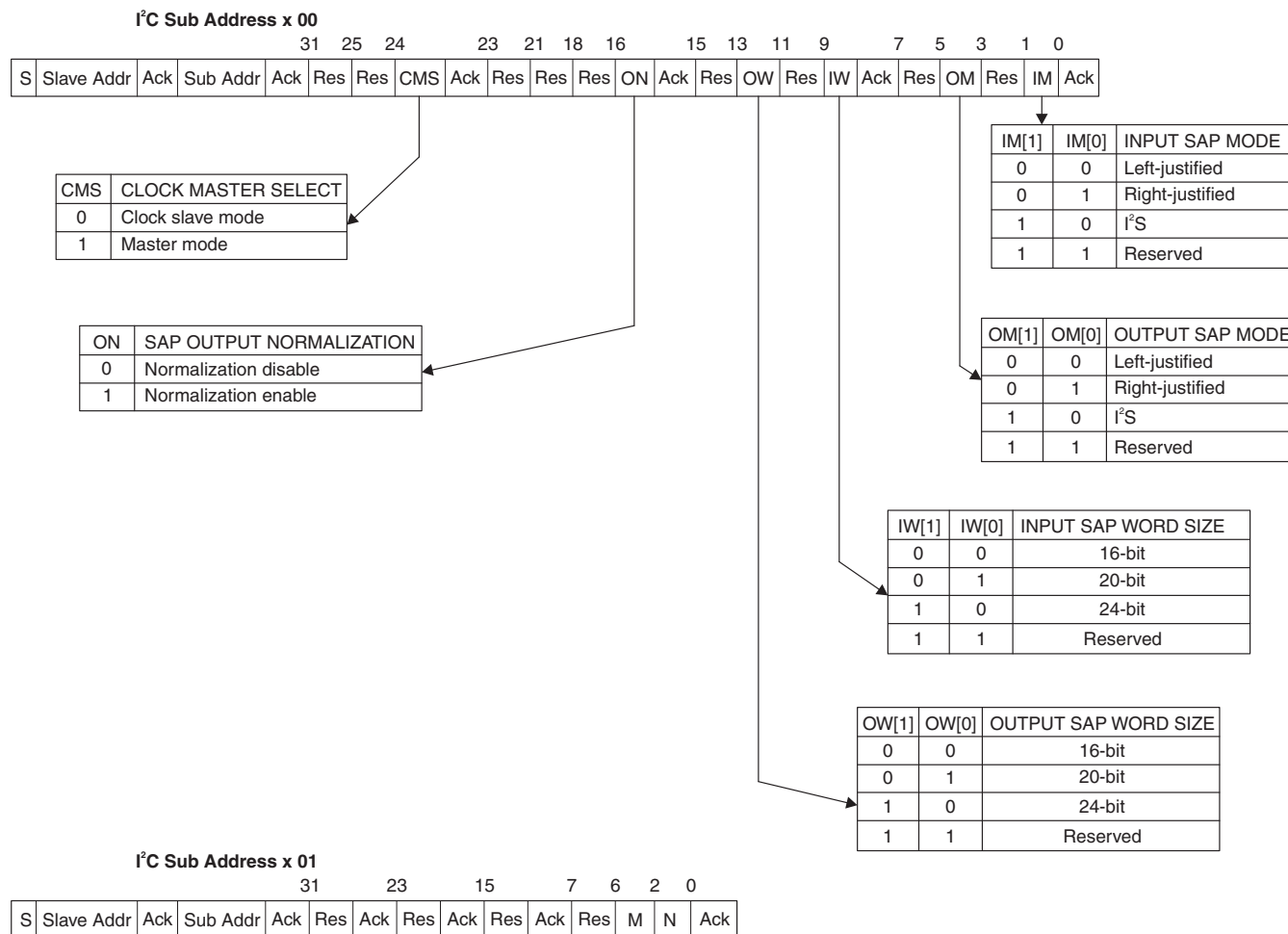

Figure 4. Clocking System I<sup>2</sup>C Mapping

**Clock Master Operation**

When configured as the device clock master, an external crystal is used as a reference to an internal oscillator. In this mode of operation, all internal clocks are generated by the oscillator.

- LRCLKOUT is fixed at 48 kHz (Fs).
- SCLKOUT is fixed at 64 × Fs.
- MCLKOUT is fixed 256 × Fs.

**Clock Slave Operation**

When configured as the device clock slave, the DAP, MCU, and I<sup>2</sup>C interface are derived from the external crystal. However, the digital audio clocks are supplied externally.

Internal analog clocks for the analog-to-digital converter (ADC) and digital-to-analog converter (DAC) are derived from the MCLKIN input. As a result, analog performance depends on the quality of MCLKIN.

Degradation in analog performance is to be expected, depending on the quality of MCLKIN.

The TAS3208 device does not include any internal clock error or click/pop detection/management. The muting of the outputs at updating of sample-rate-dependent coefficients must be initiated by the host system controller.



**Discrete Left-Justified (LJ) Timing**

Left-justified timing uses an LRCLK to define when the data being transmitted is for the left channel or right channel. The LRCLK is HIGH for the left channel and LOW for the right channel. A bit clock running at  $64 \times F_s$  is used to clock in the data. The first bit of data appears on the data lines at the same time the LRCLK toggles. The data is written MSB first and is valid on the rising edge of bit clock. The TAS3208 will mask unused trailing data bit positions.

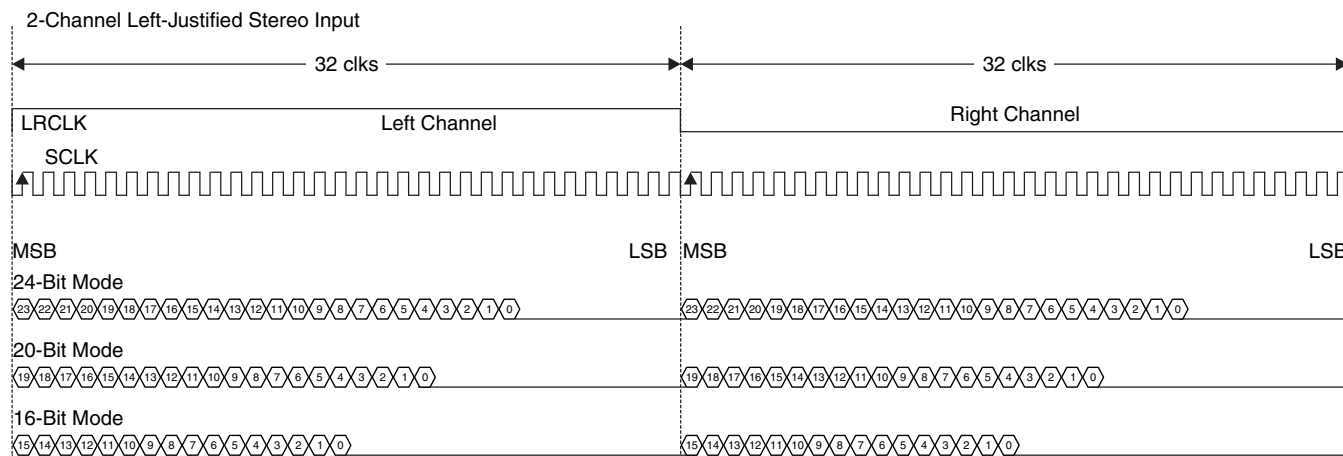

A. All data are presented in 2's complement form with MSB first.

**Figure 6. SAP Left-Justified  $64 \times F_s$  Format**

**Discrete Right-Justified (RJ) Timing**

Right-justified timing uses an LRCLK to define when the data being transmitted is for the left channel or right channel. The LRCLK is HIGH for the left channel and LOW for the right channel. A bit clock running at  $64 \times F_s$  is used to clock in the data. The first bit of data appears on the data 8-bit clock periods (for 24-bit data) after L/RCLK toggles. In RJ mode, the LSB of data is always clocked by the last bit clock before L/RCLK transitions. The data is written MSB first and is valid on the rising edge of bit clock. The TAS3208 will mask unused leading data bit positions.

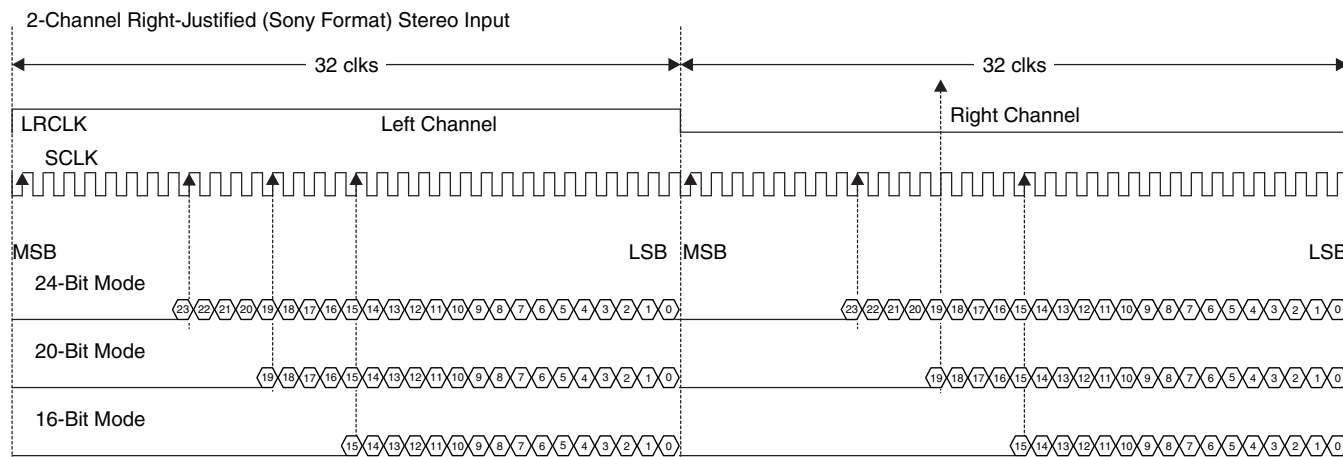

A. All data are presented in 2s-complement form with MSB first.

**Figure 7. SAP Right-Justified  $64 \times F_s$  Format**

### SAP Input and Output Normalization

The TAS3208 supports SAP input and SAP output normalization. This supports simultaneous output to left-justified and I<sup>2</sup>S devices.

**NOTE:**

The normalization function is only available in slave mode.

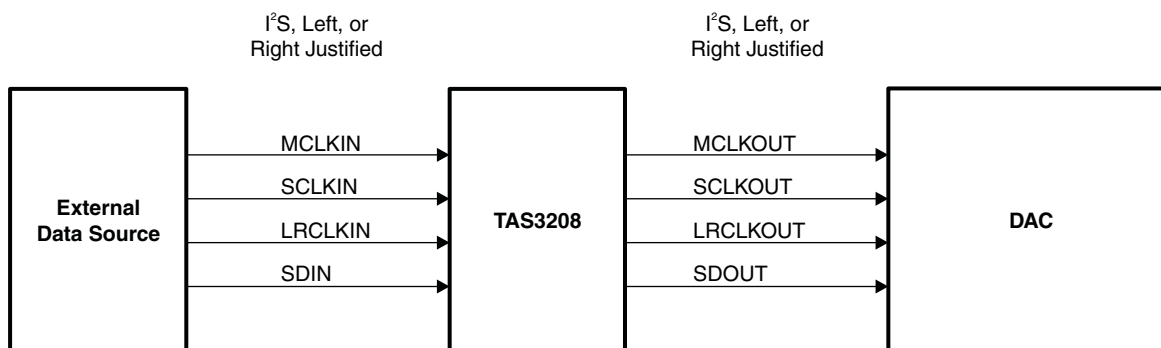

**Figure 8. SAP Output Normal Configuration (No Normalization)**

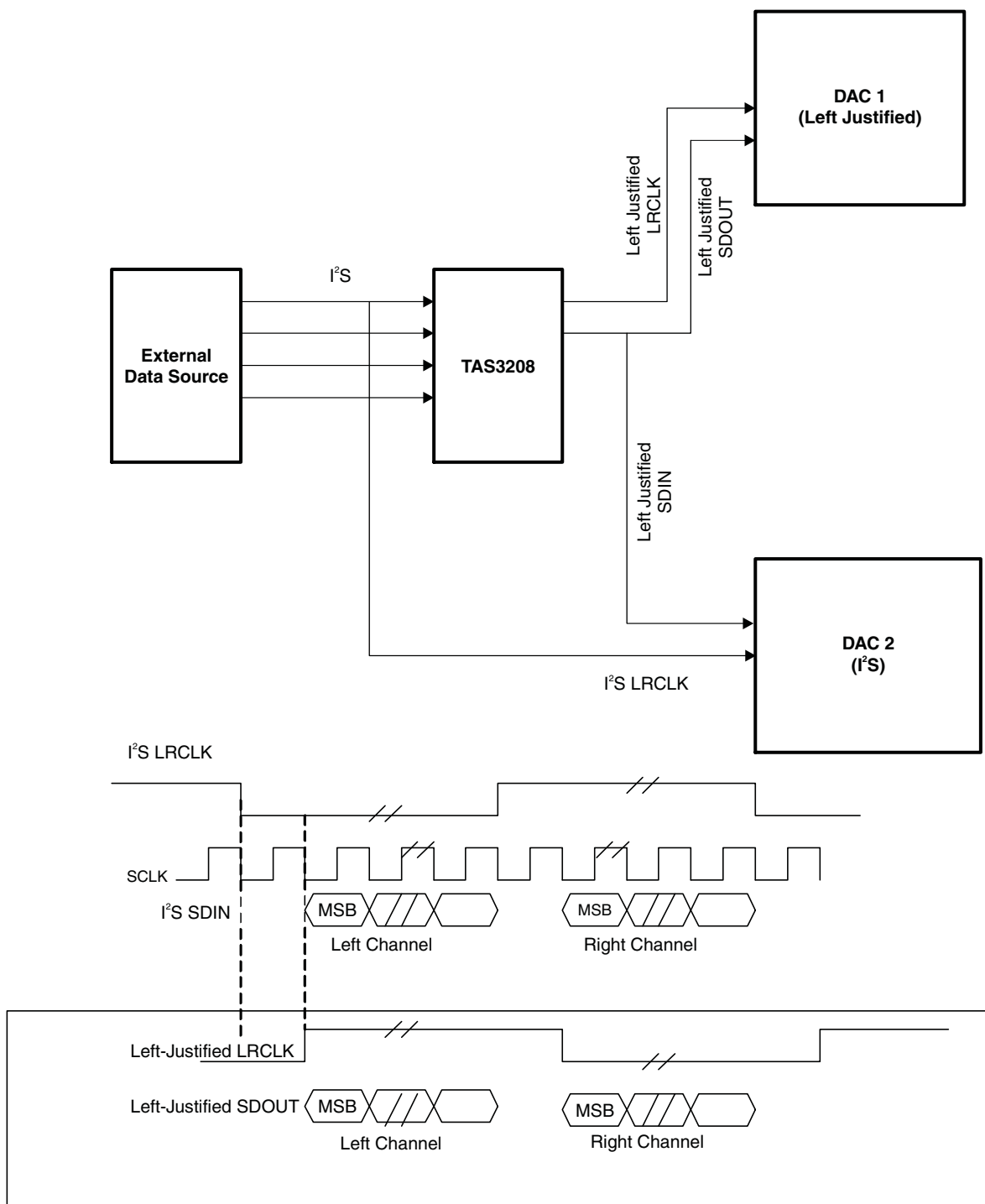

Figure 9. SAP Output Configuration (I<sup>2</sup>S to Left Normalization ON)

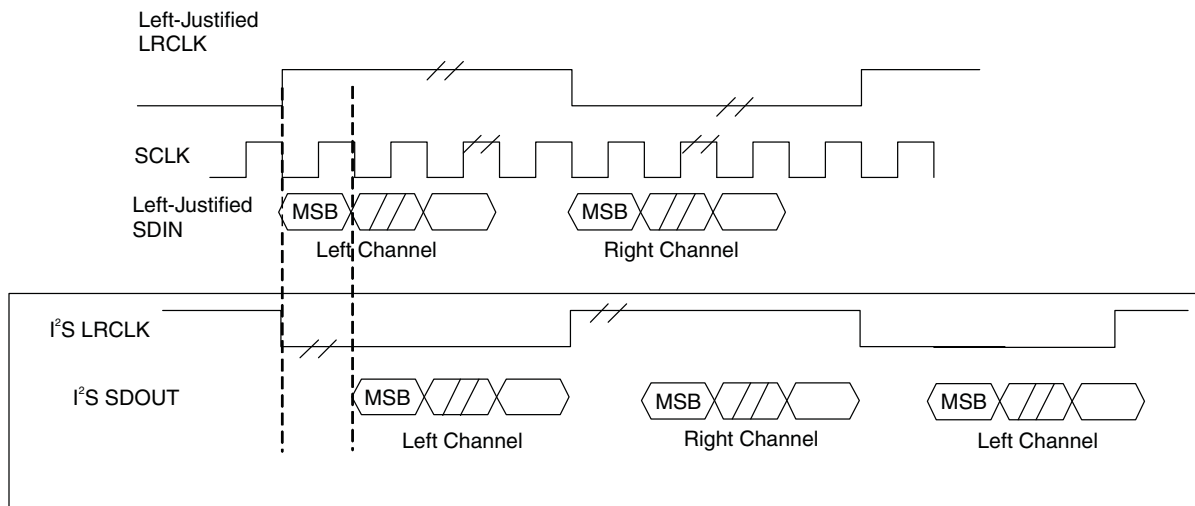

Figure 10. SAP Output Configuration (I<sup>2</sup>S to Left Normalization OFF)

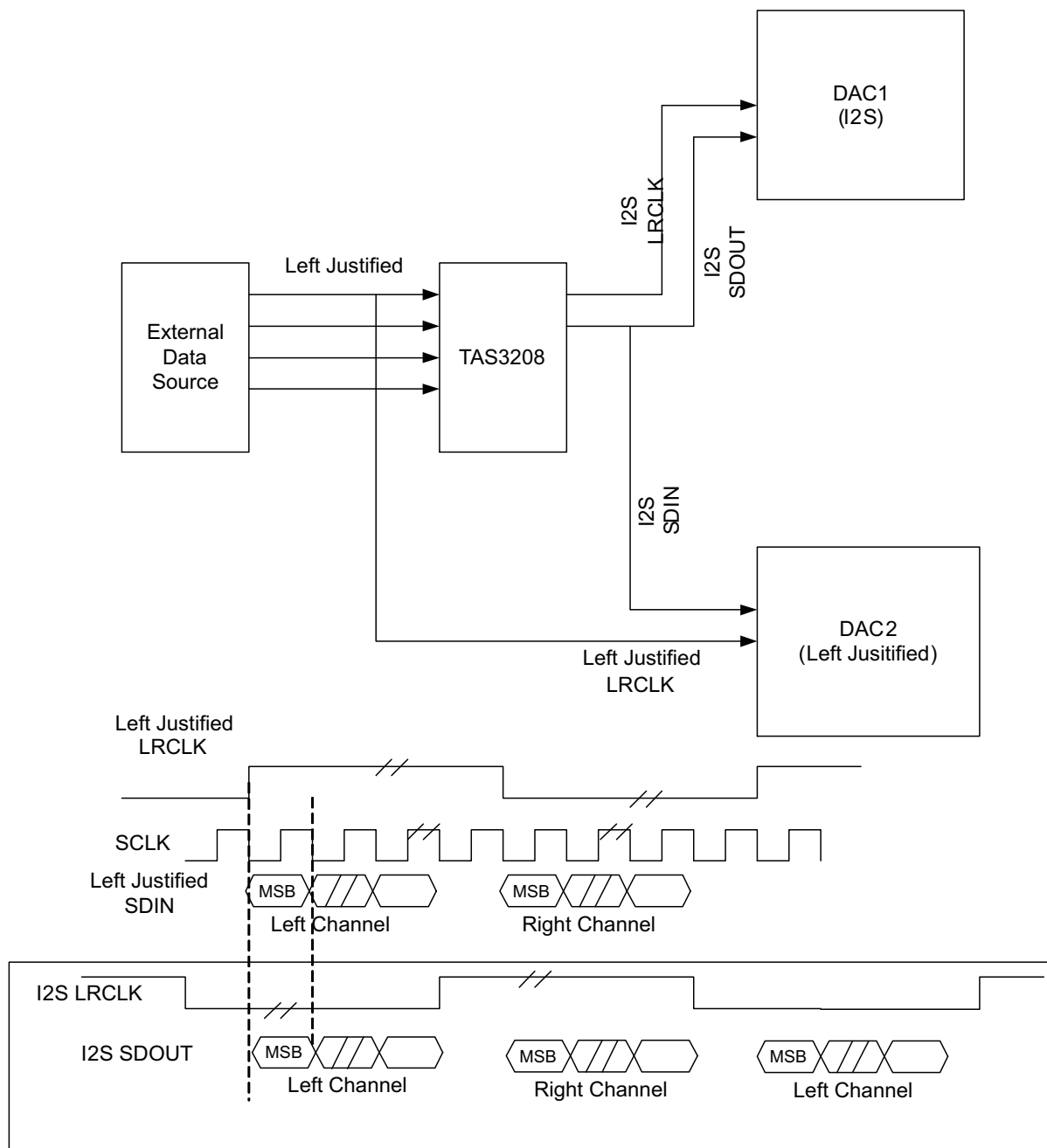

Figure 11. SAP Output Configuration (Left to I<sup>2</sup>S Normalization ON)

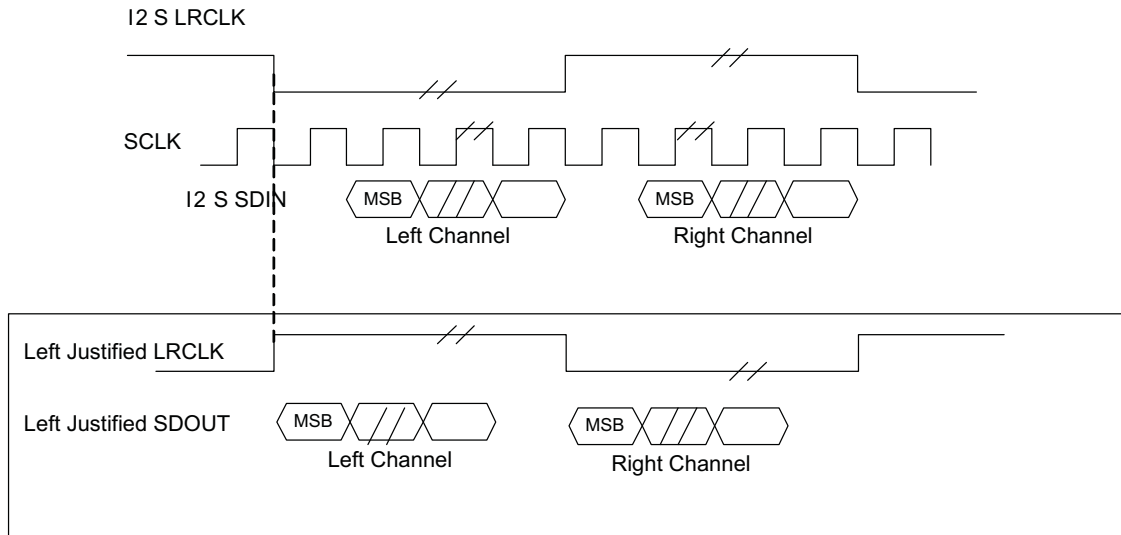

Figure 12. SAP Output Configuration (Left to I<sup>2</sup>S Normalization OFF)

**SPDIF Encoder**

The SPDIF encoder is a digital audio transmitter designed for use in consumer audio applications. Transmit data rates up to 48 kHz are supported. The SPDIF encoder complies with the IEC 60958 interface standard.

The SPDIF encoder creates a multiplexed bit stream containing audio, status, and user data. The multiplexed data format is shown in Figure 14. The data is then biphasic mark encoded and output.

The hardware architecture of the SPDIF encoder is shown in Figure 13.

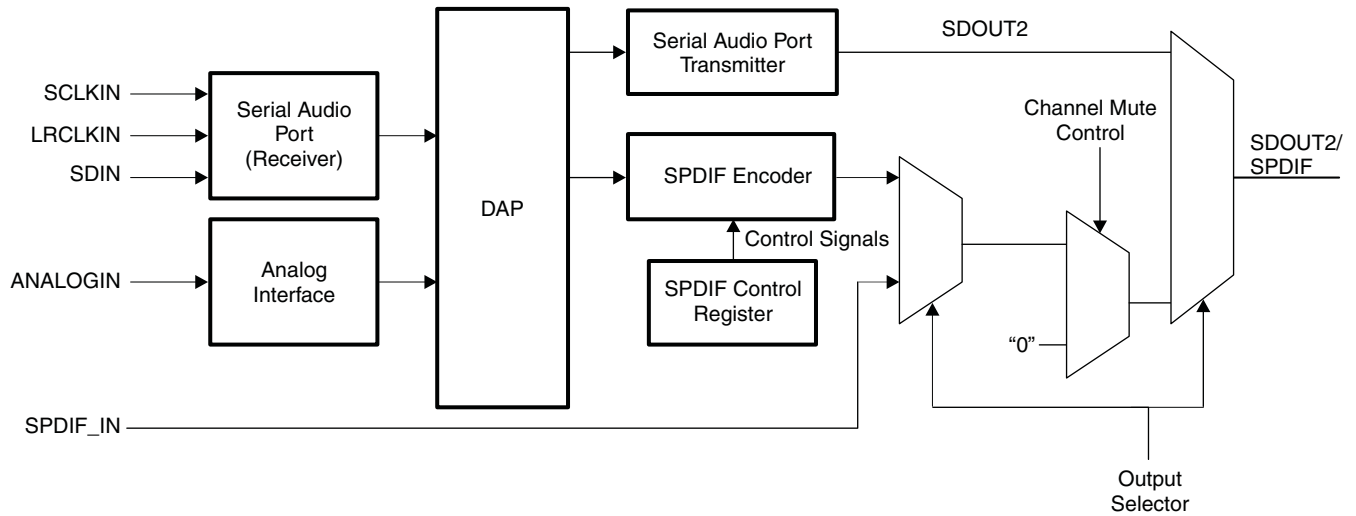

Figure 13. SPDIF Encoder Hardware Architecture



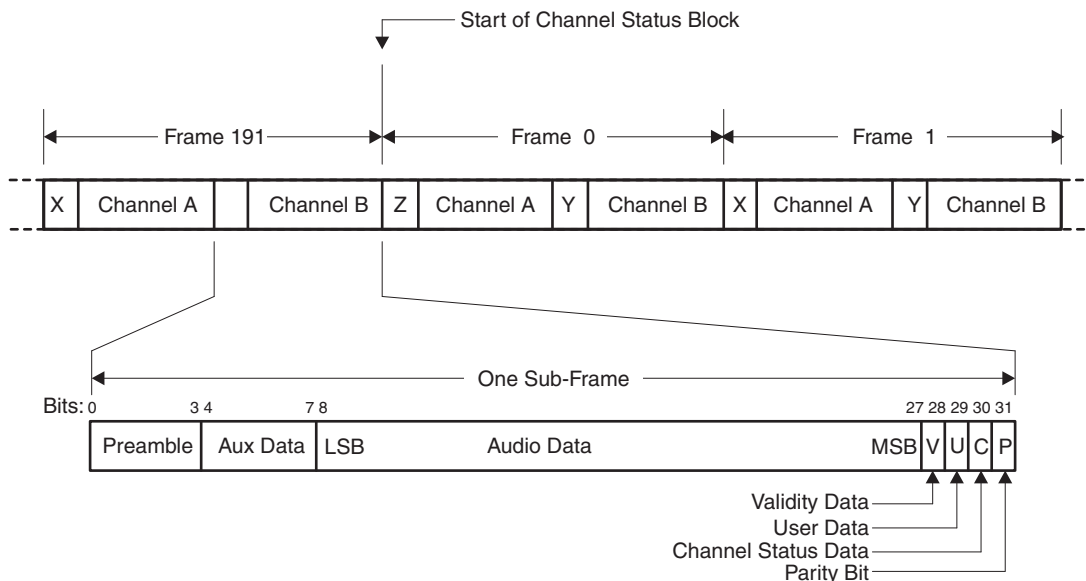

Figure 14. SPDIF Frame Format

**SPDIF Encoder Operation**

The SPDIF encoder performs the multiplexing of audio, channel status, user, and validity flag. It also performs biphasic mark encoding of the multiplexed data stream. Audio data for both left and right channels from the DAP are latched at the rising edge of the internal LRCLK, which marks the beginning of next sample cycle. The SPDIF encoder then multiplexes these samples with internally-generated preambles, channel status, user data, validity flag, and parity. The channel status and validity flag are generated based on the settings in the SPDIF control registers, while the user data is fixed to all zero. The biphasic mark-encoded signal is then output starting at the next rising edge of the internal LRCLK. The generated SPDIF stream is fixed to consumer-mode linear audio PCM format.

While the  $\overline{\text{RESET}}$  input is low, the transmitter output (SPDIF\_OUT) is forced to logic low level. Upon setting  $\overline{\text{RESET}}$  high, the SPDIF encoder remains inactive until the module reset is removed by writing 0 to the RST bit of the control register. Then this module will wait for synchronization with the internal frame clock and start encoding audio data. It is recommended to set all other SPDIF control register bits before releasing the module reset.

**Transmitter Control Register**

Table 1 shows the M8051 SFR register map for the SPDIF module control.

Table 1. M8051 SFR Register Map

ADDR	7	6	5	4	3	2	1	0
xx00	RST				CP			EMP
xx01	CATEGORY							L
xx10	SR		VL	VR	SRCNUM			
xx11			CLKAC		WORDLEN			

The relationship of the M8051 SFR register map with I<sup>2</sup>C registers is described in Table 2.

**Table 2. Relationship of M8051 SFR Register Map With I<sup>2</sup>C Registers**

RST 0 1	Module reset Normal operation Reset SPDIF TX module (default)
CP 0 1	Copy permit Copy prohibit (default) Copy permit
EMP 0 1	Preemphasis No preemphasis (default) 50-/15- $\mu$ s 2-channel preemphasis
CATEG ORY	Category code 7-bit device category code (default "0101010") (digital sound processor)
L 0 1	Generation status Generation 1 or higher (default) Original
SR 00 01 10 11	Sampling rate 44.1 kHz 48 kHz (default) Reserved 32 kHz
VL 0 1	Validity for left channel Left-channel data is valid (default) Left-channel data is invalid
VR 0 1	Validity for right channel Right-channel data is valid (default) Right-channel data is invalid
SRCNU M "0000" "0001" "0010" "0011" • • • • "1000"	Source channel number Not specified 1 2 (default) 3 • • • • 8
CLKAC "00" "01" "10" "11"	Clock accuracy Level II, 1000 ppm Level III, variable pitch shifted Level I, 50 ppm (default) Reserved
WORD LEN "0000" "0001" "0010" • • • • "0100" • • • • "1000" Others	Sample bit size 24 bits (default) 23 bits 22 bits • • • • 20 bits • • • • 16 bits Reserved

***I<sup>2</sup>C Register Map for SPDIF***

Figure 15 shows system-accessible I<sup>2</sup>C register mapping for controlling the SPDIF module. The mute control (MTE) uses the same control bits for controlling SDOOUT2 mute at subaddress 0x09, and the module reset (RST) is mapped to subaddress 0x10 together with other power-down control bits. Other control bits are mapped to subaddress 0x16.

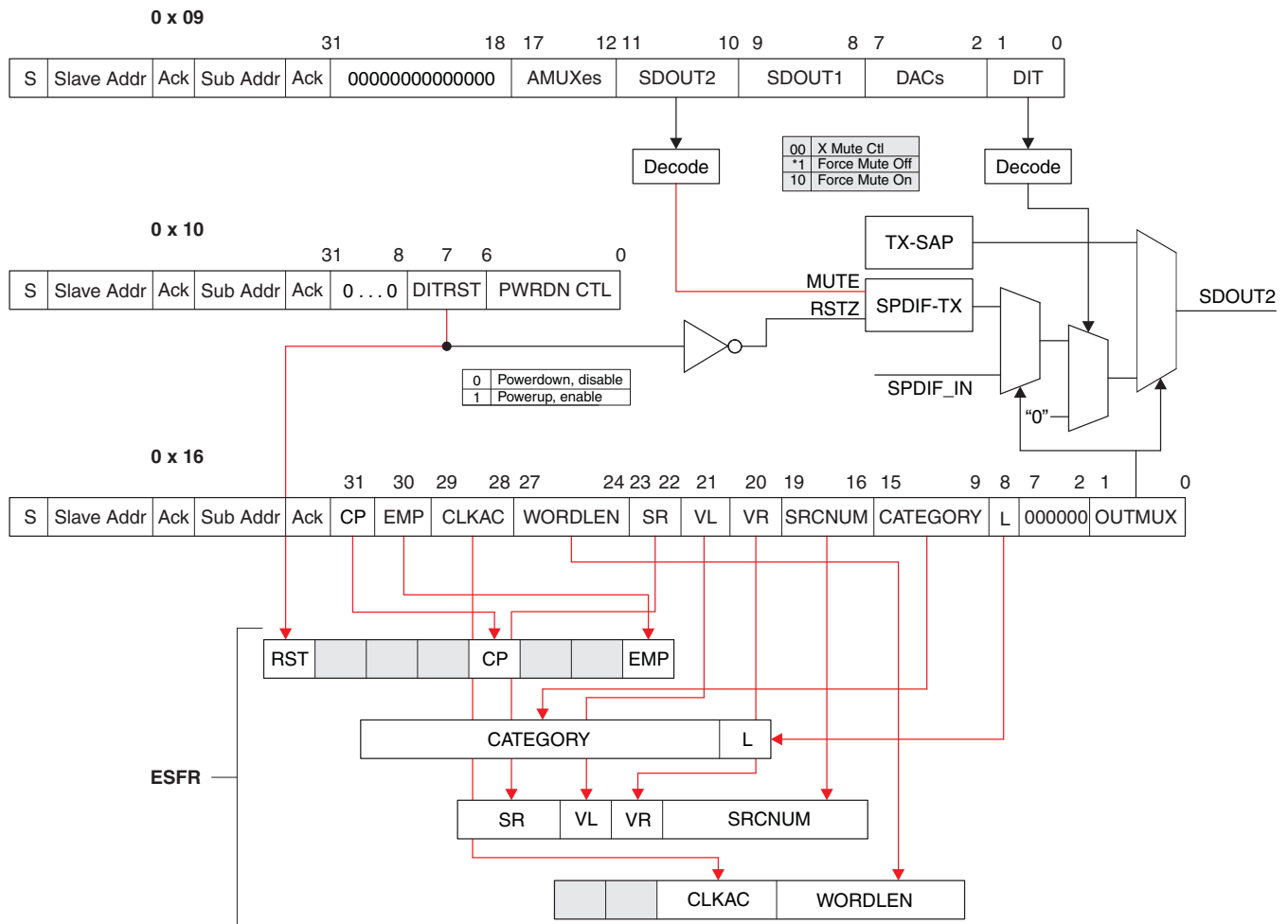

Figure 15. I²C Register to EFSR and Hardware Connection Map

**Specification Coverage**

The TAS3208 is covered by the following specifications:

- IEC 60956-1: Second Edition, 2004-03
- IEC 60956-3: Second Edition, 2003-01
- IEC 958-2: First Edition, 1994-07

Specification coverage details can be found in [Table 3](#).

**Table 3. TAS3208 Specification Coverage<sup>(1)</sup>**

SPECIFICATION	SECTION	SUPPORTED	REMARKS
IEC 60958-1	Interface Format (4)	Yes	Auto frame formatting
	Channel Status (5)	Yes	First two bits fixed to 00 (consumer, linear PCM)
IEC 958-2	Mode 1 (software info delivery using b32–191 of channel stat) (4.2.2.1–4.2.2.3)	No	Bits 28–191 fixed to all zero
IEC 60958-3	Channel Status – General (5.1)	Yes	First channel status bit fixed to 0
	Channel Status – Application (5.2.1) – Byte0 (control)	Yes	b0–1: Fixed (00) b2: Register settable b3–5: Register settable b6–7: Fixed (00)
	Channel Status – Application (5.2.2) – Byte1 (category)	Yes, with restriction	Category code is register settable, with default value 0101010L (digital sound processor), but user data is fixed to all zero.
	Channel Status – Application (5.2.2) – Byte2 (source and channel number)	Yes	b16–19: Register settable b20–23: H/W auto set (1 for left, 2 for right channel)
	Channel Status – Application (5.2.2) – Byte3 (sampling freq and clock accuracy)	Yes, with restriction	b24–27: Register settable (32, 44.1, 48 kHz only) b28–29: Register settable
	Channel Status – Application (5.2.2) – Byte4 (word length, original sampling rate, Byte0, b1, 6, 7 = “0”)	Yes, partially	b32–35 : H/W auto set according to register setting, 24-bit original output sample truncated to the specified word length b36–39 : Fixed to all zero (not indicated)
	Category Code Groups (5.3.2)	Yes, with restriction	Specifying categories other than 0101010L (digital sound processor), especially those requiring nonzero user data is not recommended.
	User Data (6)	All zero	
	Timing Accuracy (7.2.1)	Yes	Clock accuracy indication is register settable. Expected to set level I (50 ppm) for master mode (XTAL source) or level II (1000 ppm) for slave mode.
	Line Driver Characteristics (7.3.2)	No	Standard output buffer. Needs external SPDIF driver (e.g., optical driver).

(1) Other sections of the specification not mentioned here are either considered irrelevant or covered elsewhere. IEC 60958-4 is specific for professional applications and, thus, irrelevant.

## Analog Audio Interface

The TAS3208 has ten analog stereo inputs that are multiplexed to one ADC. Additionally, the TAS3208 has one line output that can source any of the ten analog stereo inputs.

The TAS3208 has three stereo DACs. The outputs of DAC3 are designed to be used as a 24-mW headphone amplifier or line driver. The other two DAC outputs are configured as stereo line drivers.

Both the ADC and DAC blocks can be placed in power down when not used.

[Figure 16](#) shows a block diagram of the analog interface.

### Stereo Analog-to-Digital Converter (ADC)

The TAS3208 has an analog 10:1 input multiplexer and an 11:1 output multiplexer. These can accept analog stereo inputs up to 1 V<sub>rms</sub>. The outputs of the multiplexers are the stereo ADC and the line output.

The ADC supports a sampling rate of 48 kHz in clock master mode. In clock slave mode, 32-, 44.1-, and 48-kHz sampling frequencies are supported, based on the master clock frequency.

### Stereo Digital-to-Analog Converters (DACs)

The TAS3208 has three stereo DACs. Each DAC can operate a maximum of 48 kHz. The DACs provide a 48-kHz sampling frequency in master mode. In slave mode, 32-, 44.1-, and 48-kHz sampling frequencies are supported, based on the master clock frequency. Two of the DACs are configured for providing line outputs. One of the stereo DACs has the capability to drive either a line out or to be used as a headphone (HP) amplifier.

The stereo HP amplifier is designed to drive up to 24 mW per channel into a headphone speaker load of 16  $\Omega$ . The headphone output is a single-ended configuration using series 16- $\Omega$  resistors and ac-coupling capacitors.

The TAS3208 includes a multiplexed stereo line driver output. The input can be selected to use the output of the stereo DAC or one of the ten sets of analog inputs. The line driver is capable of driving up to a 10-k $\Omega$  load.

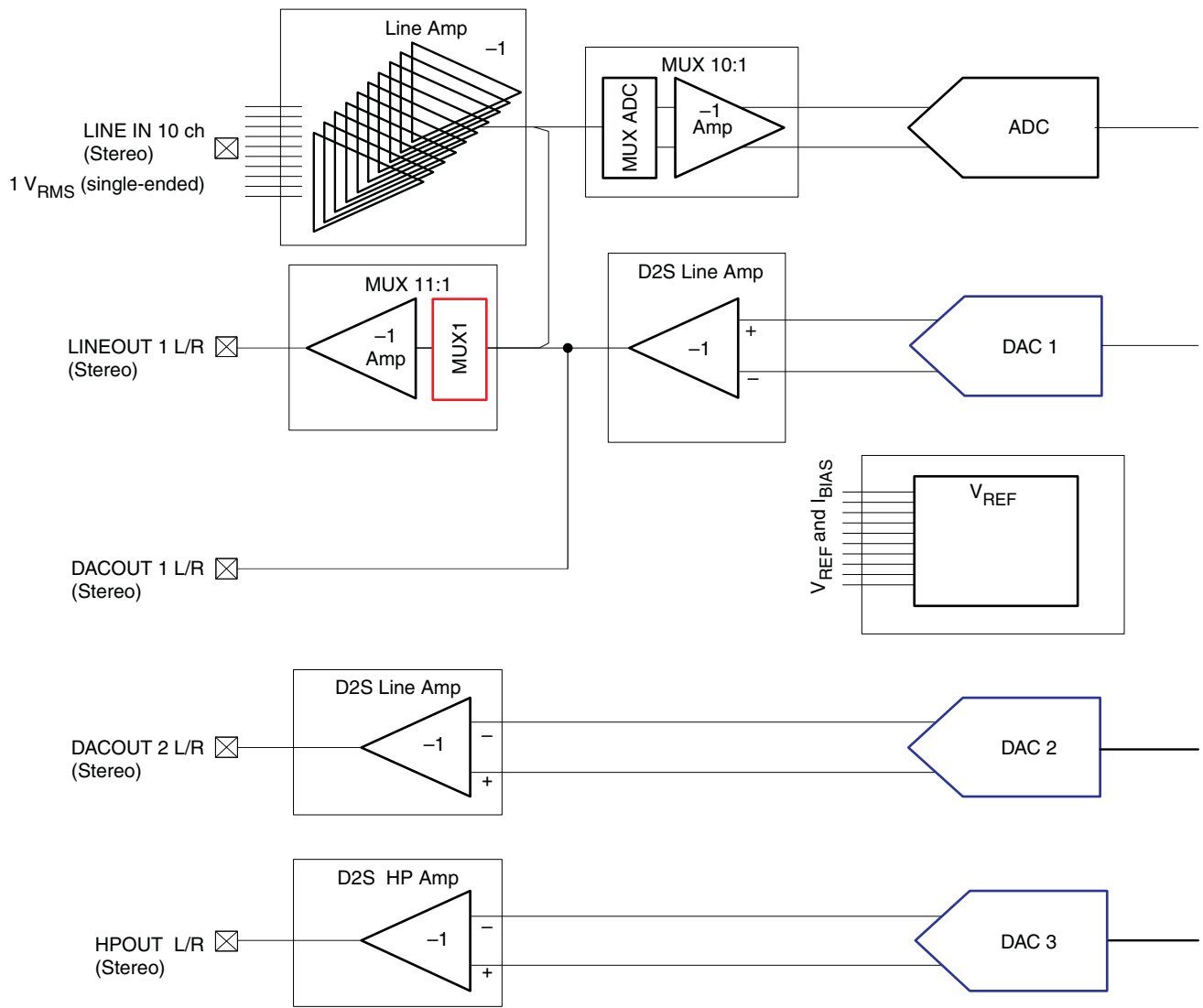

Register Map for MUTE Control

0x09

Pin Name	BIT	MUTE Block
LINEOUT1	13 12	MUX1

Pin Name	BIT	MUTE Block
DACOUT1	7 6	DAC 1

Pin Name	BIT	MUTE Block
DACOUT2	5 4	DAC 2

Pin Name	BIT	MUTE Block
HPOUT	3 2	DAC 3

DESCRIPTION		
0	0	HW Mute control
*	1	Force MUTE OFF
1	0	Force MUTE ON

Figure 16. Analog Input/Output

## Embedded M8051 WARP Microcontroller

The embedded M8051 WARP microcontroller provides the overall control for the TAS3208 device. This control includes device initialization, memory loading, I<sup>2</sup>C transactions, control-pin operations, and participation in most processing tasks requiring multiframe processing cycles.

The microcontroller has its own data RAM for storing intermediate values and queuing I<sup>2</sup>C commands, a fixed boot program ROM, and a programmable program RAM. The microprocessor's boot program cannot be altered. The microcontroller has specialized hardware for a master and slave interface operation, volume updates, and a programmable interval timer interrupt.

### M8051 Addressing Modes

The 256 bytes of internal data memory address space are accessible using indirect addressing instructions (including stack operations). However, only the lower 128 bytes are accessible using direct addressing. The upper 128 bytes of direct address data memory space are used to access external special function data registers (ESFRs).

### Register Banks

There are four directly addressable register banks, only one of which may be selected at one time. The register banks occupy Internal data memory addresses from 00 hex to 1F hex.

### Bit Addressing

The 16 bytes of internal data memory that occupy addresses from 20 hex to 2F hex are bit addressable. ESFRs that have addresses in the form 1XXXX000 binary are also bit addressable.

### Scratch Pad

Internal data memory occupying direct addresses from 30 hex to 7F hex can be used as scratch-pad registers or for the stack.

### External Data Memory

External data RAM occupies a 64K address space. This space contains ESFRs. ESFRs permit access and control of the hardware features and internal interfaces of the TAS3208 DSP.

### M8051 Boot-Up Sequence

[Figure 17](#) shows the boot-up sequence. M8051 MCU ROM code follows this sequence after device reset release. After the micro completes the boot-up application code (RAM code), the microcontroller switches the program counter from ROM to RAM code by `pc_source(esfr - 0xFD)`.

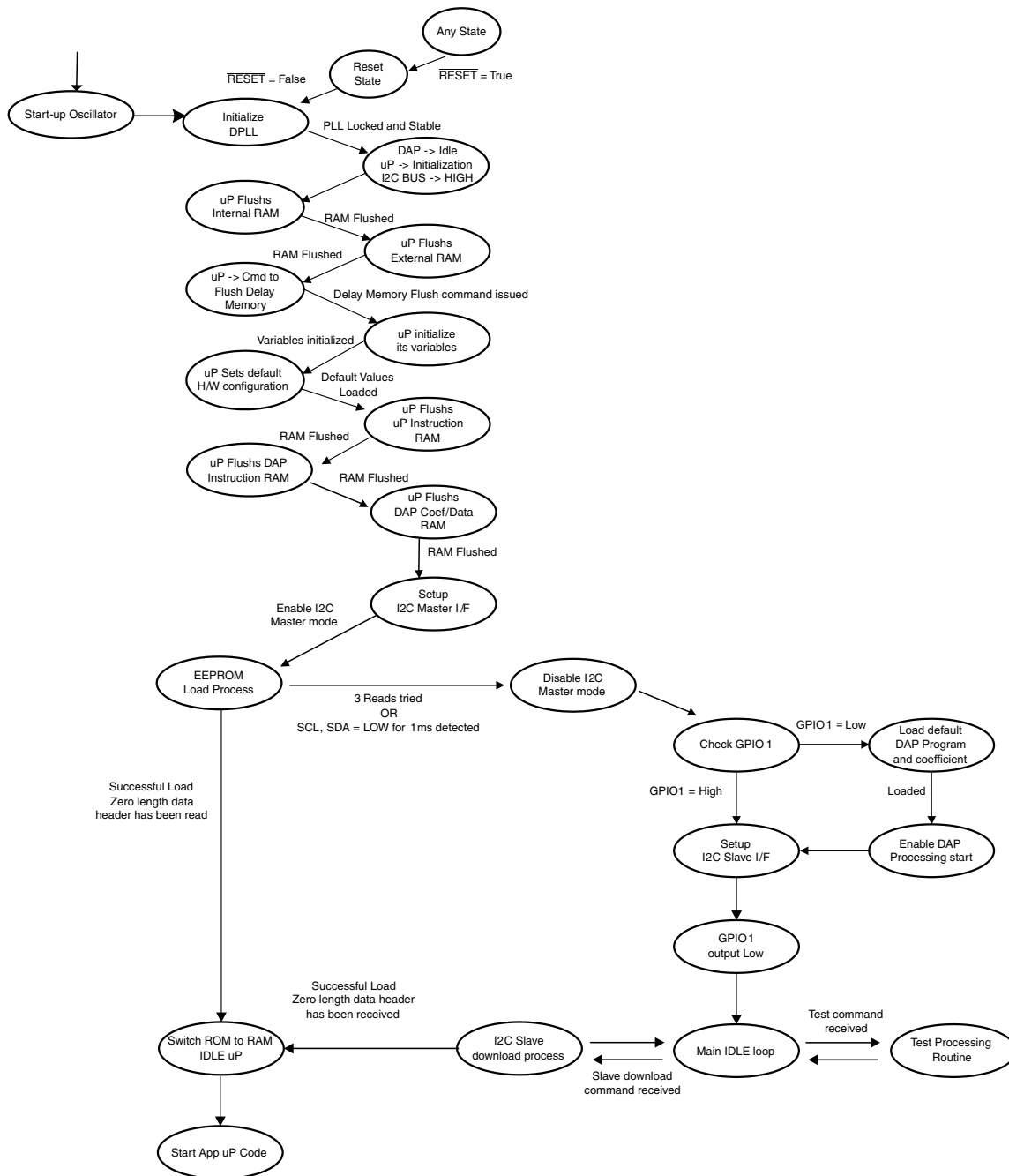

Figure 17. Boot-Up Sequence

Detailed information about the boot-up sequence is given in [Table 4](#).



**Table 4. Process Description**

PROCESS STATE	ESFR		DESCRIPTION
DSP → idle uP → initialization I <sup>2</sup> C bus → high			
uP flush internal RAM			Clear micro internal RAM (256 byte)
uP flush external RAM			Clear micro external RAM (2048 byte)
uP command to flush delay memory	clr_dly_ram (0xc0 bit(3))	1	
uP initialize variables			Initialize variables
uP set default H/W configuration	mute0_t	0	Default mutez control
	mute1_t	0	
	mute2_t	0	
	reset_dac_mod	0xff	
	reset_adc_sinc	0x03	
	clock_control1	0x0a	
	clock_delay_control2	0x05	
	clock_delay_sel	0x80	
	i2s_word_byte	0x22	IW/OW: 24 bit IM/OM: I <sup>2</sup> S
	i2c_mode_byte	0x22	
	sap_en	1	
uP flush uP instruction RAM	mem_sel	0x02	Clear uP instruction RAM (16384 byte)
uP flush DSP instruction RAM	mem_sel	0x01	Clear DSP instruction RAM (3328 W)
uP flush DSP lower coefficient/data RAM	mem_sel	0x00	Clear DSP lower coefficient RAM (1024 W) and data (48 bit) RAM (768 W)
Enable I <sup>2</sup> C master interface			Setup I <sup>2</sup> C master interface mode (enable interrupt 10)
EEPROM load			
Disable I <sup>2</sup> C master mode and enable slave interface	i2c_ms_ctl	0	Switch control MUX to slave I <sup>2</sup> C port
Switch ROM to RAM	pc_source	1	
Load default DSP Program and coefficient	host_dsp	0	<pre>                     If (gpio_in_3_0 == 1) {                     Host_dsp = 1; /* keep DSP turned off */                     } else {                     Host_dsp = 0; /* turn on DSP */                     }                 </pre>
GPIO1 output low			Enable GPIO output mode, and output low

## Control Pins

### RESET

$\overline{\text{RESET}}$  is an asynchronous control signal that restores all TAS3208 components to the default configuration. When a reset occurs, the digital audio processor (DAP) is put into an idle state and the M8051 MCU starts initialization. A reset can be initiated by inputting logic 0 on the reset pin. A reset will also be issued at power-up sequencing by the internal 1.8-V regulator power subsystem.

#### NOTE:

There is a 1.3- $\mu\text{s}$  deglitch filter on  $\overline{\text{RESET}}$ .

During a power up sequencing process,  $\overline{\text{RESET}}$  should be held low until the DVDD and AVDD power inputs have reached a voltage of 3 V.

As long as  $\overline{\text{RESET}}$  is held a logic 0, the device is in the reset state. During this reset state, all I<sup>2</sup>C and serial data bus operations are ignored. The I<sup>2</sup>C interface SCL and SDA lines goes HIGH and remain in that state until device initialization has completed.

### Power-Up Sequence

The rising edge of the  $\overline{\text{RESET}}$  pin begins the initialization of housekeeping functions by clearing memory and setting the default register values. After housekeeping initialization is complete, the TAS3208 enables the master I<sup>2</sup>C interface. The TAS3208 then uses the master I<sup>2</sup>C interface to determine if an external memory device is present.

### External Memory Device Present

Using the master I<sup>2</sup>C interface, the TAS3208 will automatically test to see if an external memory device is at address 1010xxx. The value xxx can be chip selects, other information, or don't care depending on the EEPROM selected.

If an external memory device is present and it contains the correct header information along with one or more blocks of program/memory data, the TAS3208 will automatically download the M8051 MCU program RAM, coefficient, and/or data RAM from the external EEPROM. This download is considered complete when an 'end of program' header is read by the TAS3208.

The memory block structure of the external memory device is available in [Master I2C Load RAM Block Formats](#).

At this point, the TAS3208 will disable the master I<sup>2</sup>C interface, enable the slave I<sup>2</sup>C interface, and start normal operation. After a successful download, the M8051 MCU program counter will be reset and the downloaded M8051 MCU and DSP application firmware will control execution.

### External Memory Device Not Present

If no external EEPROM is present or if an error occurred during the external memory device read, the TAS3208 will disable the master I<sup>2</sup>C interface, enable the slave I<sup>2</sup>C interface. The default slave configuration will then be loaded from the ROM into the M8051 MCU and DSP. In this default configuration, the TAS3208 will stream audio from input to output if the GPIO1 pin is pulled LOW.

#### NOTE:

The master and slave interfaces do not operate simultaneously, thus when one interface is enabled, the other is disabled.

### I<sup>2</sup>C Chip Select (CS)

The CS pin on the TAS3208 allows up to two TAS3208 devices to be addressed by the I<sup>2</sup>C bus via an external host controller, without the need for external logic. [Table 5](#) and [Table 6](#) list the I<sup>2</sup>C address for each I<sup>2</sup>C interface.

**Table 5.**  
**I<sup>2</sup>C Slave Addressing**

SLAVE ADDRESS	CS
0x68/69	0
0x6A/6B	1

**Table 6.**  
**I<sup>2</sup>C Master Addressing**

SLAVE ADDRESS	CS
0xA0/A1	0
0xA2/A3	1

### General-Purpose Input/Output (GPIO) Pins

The TAS3208 has two level-sensitive GPIO pins, GPIO1 and GPIO2, that are firmware programmable. Upon power up or following a  $\overline{\text{RESET}}$ , GPIO1 becomes an input and has a special function as described in [GPIO1 Pin Function](#).

### **GPIO1 Pin Function**

- After **RESET** or power-up initialization, if no EEPROM is present, a memory error occurs, or SDA and SCL are pulled LOW for 1 ms, then TAS3208 will disable the master I<sup>2</sup>C interface and enable the slave I<sup>2</sup>C interface initialization, to load the slave default configuration.
  - When GPIO1 has been pulled HIGH through a 10-kΩ to 20-kΩ resistor, the TAS3208 will then initialize in the default configuration with the serial data outputs not active. Once the TAS3208 has completed its default initialization procedure, with the Status register updated and the I<sup>2</sup>C slave interface enabled, GPIO1 will become an output and will be driven LOW. Following the HIGH to LOW transition of GPIO1, the system controller can access the TAS3208 through the I<sup>2</sup>C interface and read the Status register to determine the load status.

If a memory read error occurs, the TAS3208 reports the error in the Status register.

- When GPIO1 has been pulled LOW through a 10-kΩ to 20-kΩ resistor to permit a simple functional device test, GPIO1 can be pulled LOW using external logic and a 10-kΩ to 20-kΩ resistor. In this case, once the TAS3208 has completed its default test initialization procedure, with the Status register updated and the I<sup>2</sup>C slave interface enabled, the TAS3208 will stream audio from the input SDIN1 to outputs SDOUT1 and SDOUT2.

At this point, GPIO1 becomes an output and will be driven LOW. If the external logic is no longer driving GPIO1 LOW after the load has completed (≈100 ms following a RESET if no EEPROM is present), the state of GPIO1 can be observed. At this point, the system controller can access the TAS3208 through the I<sup>2</sup>C interface and read the Status register to determine the load status.

#### **NOTE:**

If the GPIO1 pin state is not observed, the only indication that the device has completed its initialization procedure is that the TAS3208 will stream audio and the I<sup>2</sup>C slave interface has been enabled.

#### **NOTE:**

Some I<sup>2</sup>C masters will hang when they receive a NAC during an I<sup>2</sup>C transaction.

- Once the TAS3208 has been programmed either through a successful boot load or via slave I<sup>2</sup>C download, the operation of GPIO1 can be programmed to be an input or an output.

### **GPIO Ports**

In I<sup>2</sup>C slave mode, the GPIO ports can be used as true general-purpose ports. Each port can be individually programmed via the I<sup>2</sup>C bus to be either an input or output port. The default assignment for all GPIO ports in I<sup>2</sup>C slave mode is an input port.

When a given GPIO port is programmed as an output port, by setting the appropriate bit in the bit field GPIODIR of subaddress 0x0C to logic 1, the logic-level output is set by the logic level programmed into the appropriate bit in bit field GPIO IN OUT. The I<sup>2</sup>C bus then controls the logic output level for those GPIO ports assigned as output ports. When a given GPIO port is programmed as an input port by setting the appropriate bit in bit field GPIODIR to logic 0, the logic input level into the GPIO port is written to the appropriate bit in bit field GPIO IN OUT. The I<sup>2</sup>C bus then can be used to read bit field GPIO IN OUT to determine the logic levels at the input GPIO ports. Whether a given bit in the bit field GPIO IN OUT is a bit to be read via the I<sup>2</sup>C bus or a bit to be written to via the I<sup>2</sup>C bus is strictly determined by the corresponding bit setting in bit field GPIODIR.

In I<sup>2</sup>C slave mode, the GPIO input ports are read every GPIOMICROCOUNT micro clocks, as was the case in the I<sup>2</sup>C master mode. However, parameter GPIO\_samp\_int does not have a role in I<sup>2</sup>C slave mode. If a GPIO port is assigned as an output port, a logic 0 bit value is supplied by the TAS3208 for this GPIO port in response to a read transaction at subaddress 0x0C.

If the GPIO ports are left in their power turnon default state, they are input ports with a weak pullup on the input to VDSS.

### Watchdog Timer

There is a hardware watchdog timer in the TAS3208 that can be programmed in the customer application code to monitor the microprocessor activity. If the watchdog timer expires, it will generate a reset to the 8051 microprocessor. GPIOMICROCOUNT, in subaddress 0x0C, is used in order to trigger GPIO and the monitoring to the DSP diagnostic count. Because of this, the value selected for GPIOMICROCOUNT must be chosen to provide a good tradeoff of between micro overhead and adequate execution frequency of these processes. The default value for this counter is 0x5820 which corresponds to a period of 1.25 ms.

Figure 18 shows the GPIO register, the GPOI interface, and a typical user application code implementation of the watchdog timer reset.

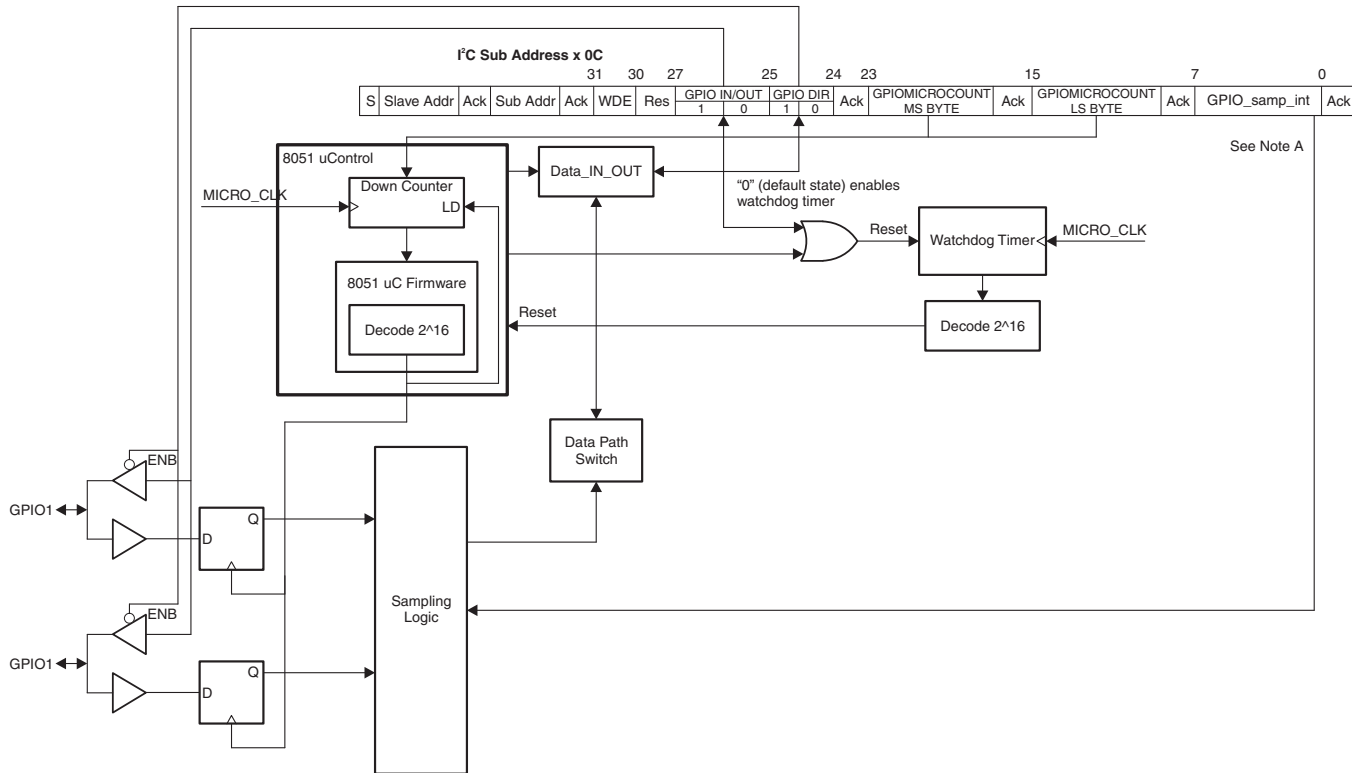

- A. Determines how many consecutive logic 0 samples (where each sample is spaced by GPIOMICROCOUNT Micro\_clks) are required to read a logic 0 on a GPIO input port

Figure 18. GPIO Ports

## I<sup>2</sup>C Control Interface

### General I<sup>2</sup>C Transactions

The M8051 microprocessor receives and distributes I<sup>2</sup>C data to the I<sup>2</sup>C bus controllers, and participates in most I<sup>2</sup>C processing tasks requiring multiframe processing cycles. The master and slave interfaces do not operate simultaneously.

The I<sup>2</sup>C communication protocol for the I<sup>2</sup>C slave mode is shown in Figure 19.

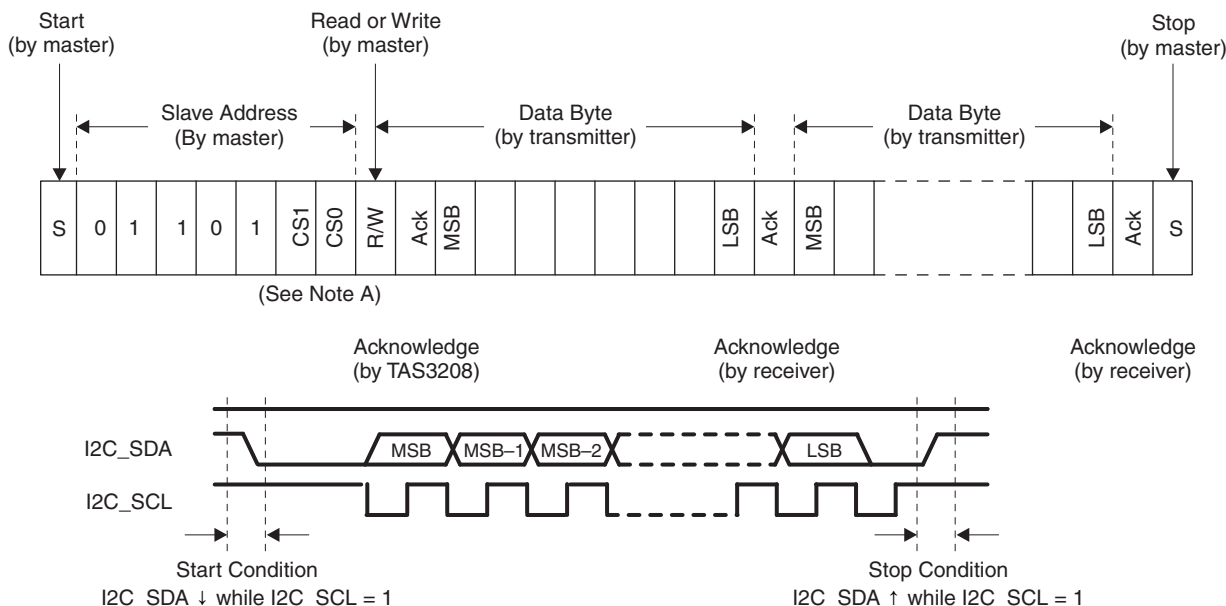

- A. Bits CS1 and CS0 in the TAS3208 slave address are compared to the logic levels on pins CS0 and CS1 for address verification. This provides the ability to address up to four TAS3208 chips on the same I<sup>2</sup>C bus.

**Figure 19. I<sup>2</sup>C Slave-Mode Communication Protocol**

The I<sup>2</sup>C bus employs two signals – SDA (data) and SCL (clock) – to communicate between integrated circuits in a system. Data is transferred on the bus serially one bit at a time. The address and data be transferred in byte (8-bit) format with the MSB transferred first. In addition, each byte transferred on the bus is acknowledged by the receiving device with an acknowledge bit. Each transfer operation begins with the master device driving a Start condition on the bus and ends with the master device driving a Stop condition on the bus. The bus uses transitions on the data (SDA) terminal while the clock is HIGH to indicate Start and Stop conditions. A HIGH-to-LOW transition on SDA indicates a Start, and a LOW-to-HIGH transition indicates a Stop. Normal data bit transitions must occur within the low time of the clock period. The master generates the 7-bit slave address and the read/write (R/W) bit to open communication with another device and then waits for an acknowledge condition. The slave holds SDA LOW during the acknowledge clock period to indicate an acknowledgement. When this occurs, the master transmits the next byte of the sequence. Each device is addressed by a unique 7-bit slave address plus R/W bit (1 byte). All compatible devices share the same signals via a bidirectional bus using a wired-AND connection. An external pullup resistor must be used for the SDA and SCL signals to set the HIGH level for the bus.

There is no limit on the number of bytes that can be transmitted between Start and Stop conditions. When the last word transfers, the master generates a Stop condition to release the bus.

A read transaction requires that the master device first issue a write transaction to give the TAS3208 the subaddress to be used in the read transaction that follows. This subaddress assignment write transaction is then followed by the read transaction. For write transactions, the subaddress is supplied in the first byte of data written, and this byte is followed by the data to be written. For write transactions, the subaddress must always be included in the data written. There cannot be a separate write transaction to supply the subaddress, as was required for read transactions. If a subaddress assignment's only write transaction is followed by a second write transaction supplying the data, erroneous behavior results. The first byte in the second write transaction is interpreted by the TAS3208 as another subaddress replacing the one previously written.

**Multiple Byte Write**

A multiple byte data write transfer is identical to a single byte data write transfer, except that multiple data bytes are transmitted by the master device to slave (see Figure 20). After receiving each data byte, the TAS3208 will respond with an acknowledge bit.

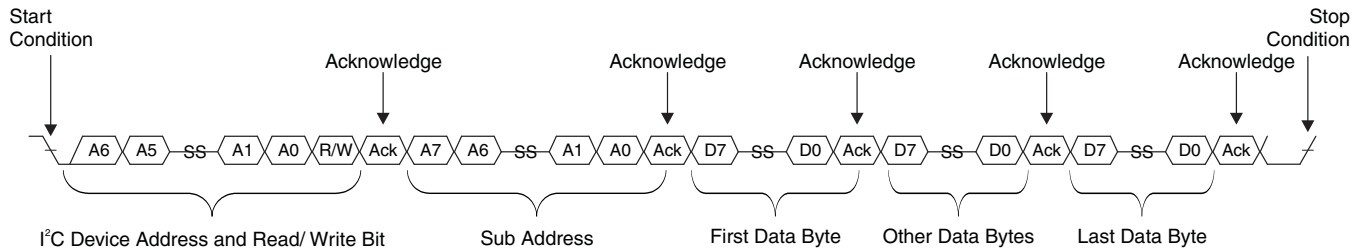

**Figure 20. Multiple Byte Write Transfer**

**Multiple Byte Read**

A multiple byte data read transfer is identical to a single byte data read transfer, except that multiple data bytes are transmitted by the TAS3208 to the master device (see Figure 21). Except for the last data byte, the master device will respond with an acknowledge bit after receiving each data byte.

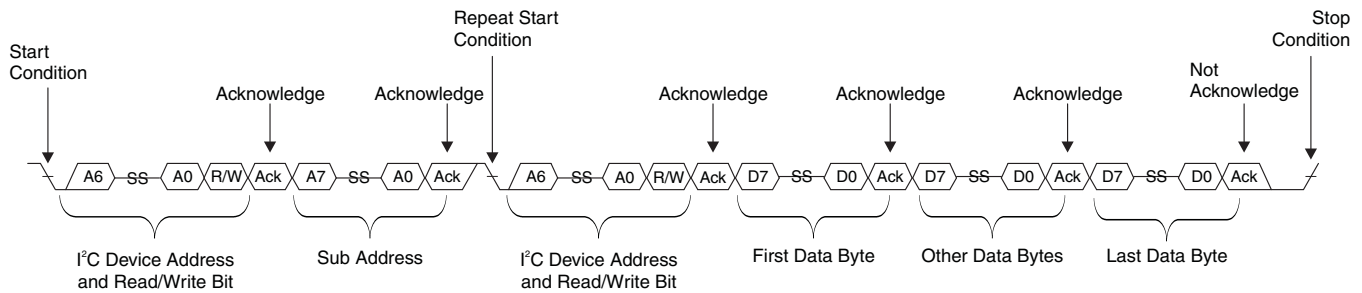

**Figure 21. Multiple Byte Read Transfer**

**Random I²C Transactions**

Supplying a subaddress for each subaddress transaction is referred to as random I²C addressing. For random I²C read commands, the TAS3208 responds with data, a byte at a time, starting at the subaddress assigned, as long as the master device continues to respond with acknowledges. If a given subaddress does not use all 32 bits, the unused bits are read as logic 0. I²C write commands, however, are treated in accordance with the data assignment for that address space. For example, if a write command is received for a biquad subaddress, the TAS3208 expects to see five 32-bit words. If fewer than five data words have been received when a Stop command (or another Start command) is received, the data received is discarded.

**Sequential I²C Transactions**

The TAS3208 supports sequential I²C addressing. For write transactions, if a subaddress is issued followed by data for that subaddress and the 15 subaddresses that follow, a sequential I²C write transaction has taken place, and the data for all 16 subaddresses is successfully received by the TAS3208. For I²C sequential write transactions, the subaddress then serves as the start address and the amount of data subsequently transmitted, before a Stop or Start is transmitted, determines how many subaddresses are written to. As was true for random addressing, sequential addressing requires that a complete set of data be transmitted. If only a partial set of data is written to the last subaddress, the data for the last subaddress is discarded. However, all other data written is accepted; just the incomplete data is discarded.

Sequential read transactions do not have restrictions on outputting only complete subaddress data sets.

If the master does not issue enough data received acknowledges to receive all the data for a given subaddress, the master device simply does not receive all the data.

If the master device issues more data received acknowledges than required to receive the data for a given subaddress, the master device simply receives complete or partial sets of data, depending on how many data received acknowledges are issued from the subaddress(es) that follow. I<sup>2</sup>C read transactions, both sequential and random, can impose wait states.

For the standard I<sup>2</sup>C mode (SCL = 100 kHz), worse-case wait state times for an 8-MHz microprocessor clock is on the order of 2 μs. Nominal wait state times for the same 8-MHz microprocessor clock is on the order of 1 μs. For the fast I<sup>2</sup>C mode (SCL = 400 kHz) and the same 8-MHz microprocessor clock, worse-case wait state times can extend up to 10.5 μs in duration. Nominal wait state times for this same case lie in a range from 2 μs to 4.6 μs. Increasing the microprocessor clock frequency lowers the wait state times and for the standard I<sup>2</sup>C mode, a higher microprocessor clock can totally eliminate the presence of wait states.

For example, increasing the microprocessor clock to 16 MHz results in no wait states. For the fast I<sup>2</sup>C mode, higher microprocessor clocks shortens the wait state times encountered, but does not totally eliminate their presence.

### I<sup>2</sup>C Master-Mode Operation

I<sup>2</sup>C master-mode operation is enabled following a reset or power-on reset.

The TAS3208 uses the master mode to download from EEPROM the memory contents for:

- Microprogram memory
- Micro extended memory
- DSP program memory
- DSP coefficient memory
- DSP data memory

The TAS3208, when operating as an I<sup>2</sup>C master, can execute a complete download of any internal memory or any section of any internal memory without requiring any wait states.

When the TAS3208 operates as an I<sup>2</sup>C master, it generates a repeated Start without an intervening Stop command while downloading program and memory DATA from an external EEPROM. When a repeated Start is sent to the EEPROM in read mode, the EEPROM enters a sequential read mode to quickly transfer large blocks of data.

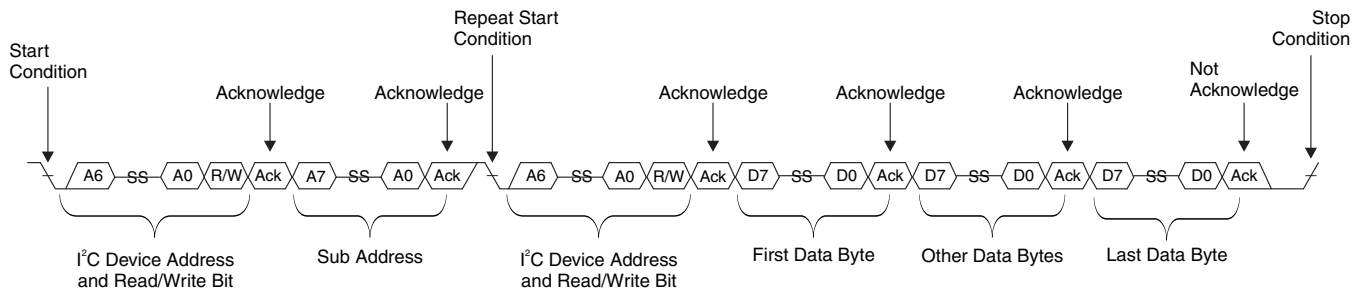

Figure 22. Multiple-Byte Read Transfer

The TAS3208 will query the bus for an I<sup>2</sup>C EEPROM at an address 1010xxx. The value xxx can be chip selects, other information, or don't cares depending on the EEPROM selected.

The first act of the TAS3208 as master will be to transmit a Start condition along with the device address of the I<sup>2</sup>C EEPROM, with the read/write bit cleared (0) to indicate a write. The EEPROM acknowledges the address byte and the TAS3208 sends a subaddress byte, which the EEPROM will acknowledge. Most EEPROMs have at least 2-byte addresses and will acknowledge as many as are appropriate. At this point, the EEPROM sends a last acknowledge and becomes a slave transmitter. The TAS3208 acknowledges each byte repeatedly to continue reading each data byte that is stored in memory.



The memory load information starts with reading the header and data information that starts at subaddress 0 of the EEPROM. This information must be stored in a sequential memory addresses with no intervening gaps. The data block is contiguous blocks of data that immediately follow the headers' locations. The TAS3208 memory data can be stored and loaded in (almost) any order. Additionally this addressing scheme permits portions of the TAS3208 internal memories to be loaded.

I<sup>2</sup>C EEPROM Memory Map

Figure 23. EEPROM Address Map

The TAS3208 will sequentially read EEPROM memory and load its internal memory unless it does not find a valid memory header block, is not able to read the next memory location because the end of memory was reached, detects a checksum error, or reads an end-of-program header block. When it encounters a valid header or read error, the TAS3208 will attempt to read the header or memory location three times before it determines that it has an error. If the TAS3208 encounters a checksum error, it will attempt to reread the entire block of memory two more times before it determines that it has an error.

**NOTE:**

Once the microprogram memory has been loaded, it can not be reloaded until the TAS3208 has been reset.

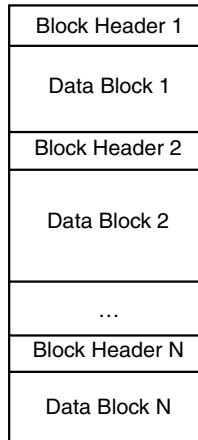
If an error is encountered, the TAS3208 terminates its memory load operation, loads the default configuration for both the M8051 MCU and DSP from the embedded ROM, and disables further master I<sup>2</sup>C bus operations.

If an end-of-program data block is read, the TAS3208 has completed the initial program load.

The I<sup>2</sup>C master mode utilizes the starting and ending I<sup>2</sup>C checksums to verify a proper EEPROM download. The first 16-bit data word received from the EEPROM is the I<sup>2</sup>C checksum at subaddress 0x00. It is stored and compared against the 16-bit data word received for last subaddress, the ending I<sup>2</sup>C checksum, and the checksum that is computed during the download. These three values must be equal. If the read and computed values do not match, the TAS3208 sets the memory read error bits in the Status register and repeats the download from the EEPROM two more times. If the comparison check again fails the third time, the TAS3208 sets the microprogram to the default value.

**NOTE:**

When acting as an I<sup>2</sup>C master, the data rate transfer is fixed at 375 kHz.



## I<sup>2</sup>C Slave Mode Operation

The I<sup>2</sup>C slave mode is the mode that is used to change configuration parameters during operation and perform program and coefficient downloads from a master device. The latter can be used to replace the I<sup>2</sup>C master mode EEPROM download.

The TAS3208 uses the slave mode to load the memory contents for the:

- Microprogram memory
- Micro extended memory
- DSP program memory
- DSP coefficient memory
- DSP data memory
- Update coefficient and other control values
- Read status flags

The TAS3208 support both random and sequential I<sup>2</sup>C transactions. The TAS3208 I<sup>2</sup>C slave address is 011010X, where the first six bits are the TAS3208 device address and the final one bit is set by the TAS3208 internal microprocessor at power up. The internal microprocessor derives the last bit from an external pin (CS), which is pulled up or down to create two unique addresses for control of multiple TAS3208 part applications. The pulldown resistance of CS creates a default 00 address when no connection is made to the pin.

The TAS3208 I<sup>2</sup>C block does respond to the broadcast address (00h).

### NOTE:

When acting as an I<sup>2</sup>C slave, data-rate transfer is determined by the master device on the bus. However, the setting of I<sup>2</sup>C parameter N at subaddress 0x01 does play a role in setting the maximum possible data transfer rate. In the I<sup>2</sup>C slave mode, bit rates other than (and including) the I<sup>2</sup>C-specific 100-Kbps and 400-Kbps bit rates can be obtained, but N must always be set so that the oversample clock into the I<sup>2</sup>C master and slave controllers is at least a factor of 20 higher in frequency than SCL.

N = 0 is a special case. When N = 0, a mode is enabled that detects I<sup>2</sup>C frames and enables the TAS3208 I<sup>2</sup>C interface to reset and continue operation after receiving an invalid I<sup>2</sup>C frame.

**Table 7.  
I<sup>2</sup>C Slave Addresses**

SLAVE ADDRESS	CS
0x68/69	0
0x6A/6B	1

**Table 8.  
I<sup>2</sup>C Master Addresses**

SLAVE ADDRESS	CS
0xA0/A1	0
0xA2/A3	1

## Digital Signal Processor (DSP) Arithmetic Unit

### Overview

The arithmetic processor is a fixed-point computational engine consisting of an arithmetic unit and data and coefficient memory blocks. The primary features are:

- Two pipe parallel processing architecture
  - 48-bit data path with 76-bit accumulator
  - Hardware single-cycle multiplier (28 × 48)
  - Three 48-bit general-purpose data registers
  - One 28-bit coefficient register
  - 48-bit adder
  - 28-bit adder
  - Shift right, shift left
  - Bimodal clip
  - Log2/Alog2
  - Magnitude truncation
- Read/read/write single-cycle memory access
- Data input is 48-bit 2s complement multiplexed in from SAP immediately following FSYNC pulse.
- Data output is four 32-bit 2s-complement buses.
- Separate control for writing to delay memory
- Separate coefficient memory (28 bit) and data memory (48 bit)
- Linear Feedback Shift Register (LFSR) in the instruction register doubles as a random number generator in normal operating mode.
- Coefficient RAM, data RAM, LFSR seed, program counter, and memory pointers are all mapped into the same memory space for convenient addressing by the micro.
- Memory interface block contains four pointers – two for data memory and two for coefficient memory.

### Data Format

[Figure 24](#) shows the data word structure of the arithmetic unit. Eight bits of overhead or guard bits are provided at the upper end of the 48-bit word, and 16 bits of computational precision or noise bits are provided at the lower end of the 48-bit word. The incoming digital audio words are all positioned with the MSB abutting the 8-bit overhead/guard boundary. The sign bit in bit 39 indicates that all incoming audio samples are treated as signed data samples.

The arithmetic engine is a 48-bit (25.23 format) processor consisting of a general-purpose 76-bit arithmetic logic unit and function-specific arithmetic blocks. Multiply operations (excluding the function-specific arithmetic blocks) always involve 48-bit words and 28-bit coefficients (usually I<sup>2</sup>C programmable coefficients). If a group of products are to be added together, the 76-bit product of each multiplication is applied to a 76-bit adder, where a DSP-like multiply-accumulate (MAC) operation takes place. Biquad filter computations use the MAC operation to maintain precision in the intermediate computational stages.

To maximize the linear range of the 76-bit ALU, saturation logic is not used. In MAC computations, intermediate overflows are permitted, and it is assumed that subsequent terms in the computation flow will correct the overflow condition.

The memory banks include a dual-port data RAM for storing intermediate results, a coefficient RAM, and a fixed-program ROM. Only the coefficient RAM, assessable via the I<sup>2</sup>C bus, is available to the user.

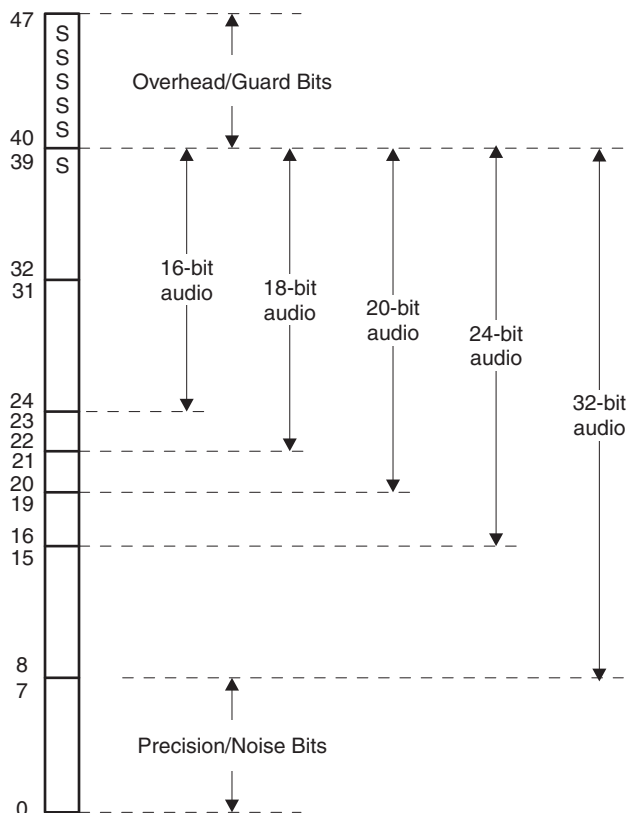

Figure 24. Arithmetic Unit Data Word Structure

8-Bit ALU Operation  
(without saturation)

	10110111	(-73)			-73
	+	11001101	(-51)		+ -51
		10000100	(-124)		-124
	+	11010011	(-45)		+ -45
Rollover →		01010111	(57)		-169
	+	00111011	(59)		+ 59
		10010010	(-110)		-110

Figure 25. DSP ALU Operation With Intermediate Overflow

DAP Data Path Data Representation

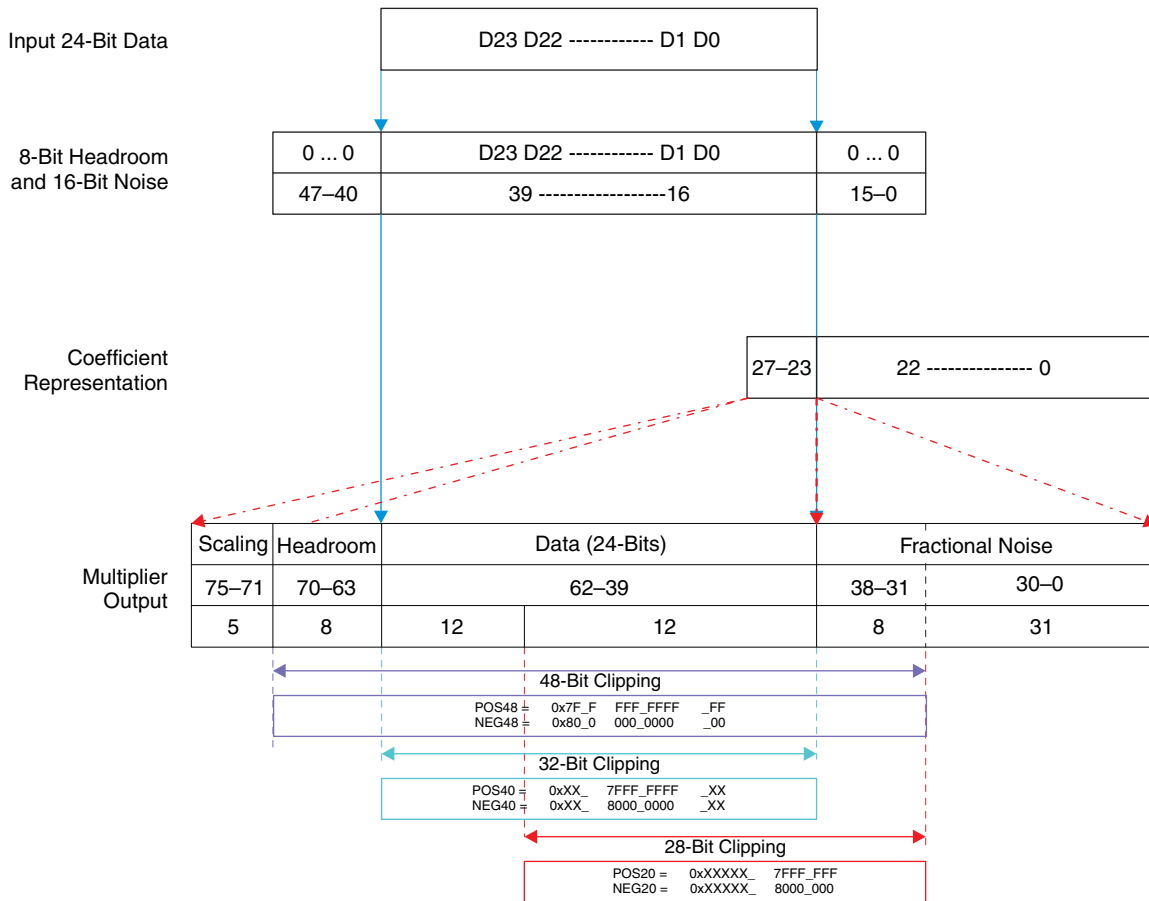

Figure 26. DSP Data-Path Data Representation

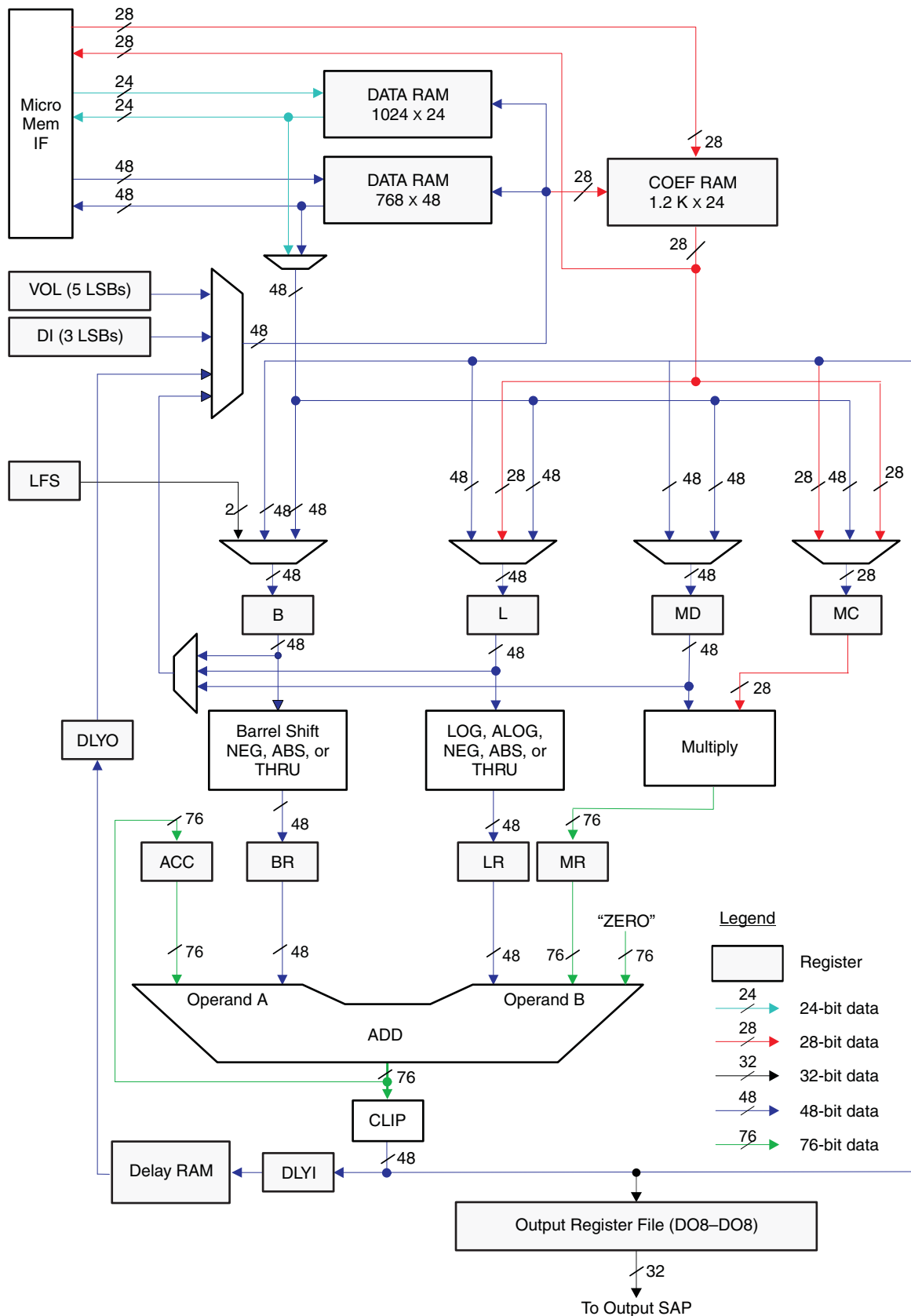

Figure 27. DSP Data-Path Architecture

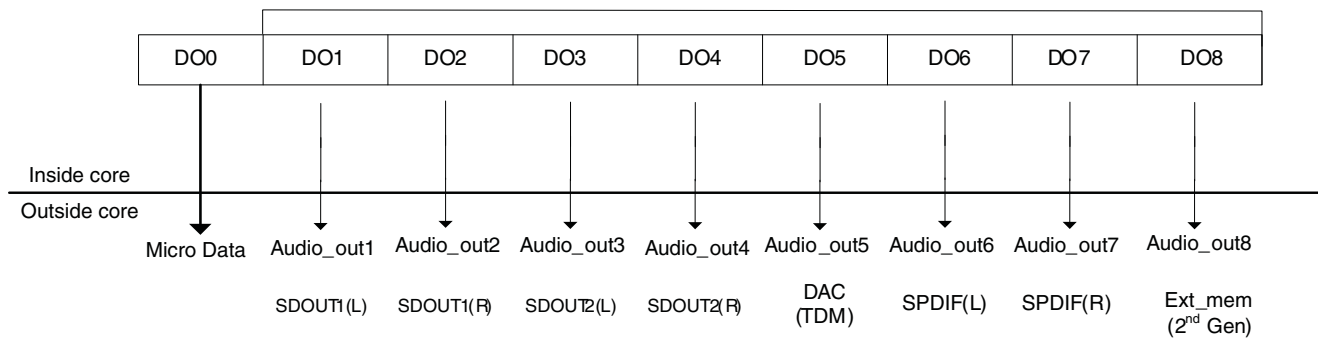
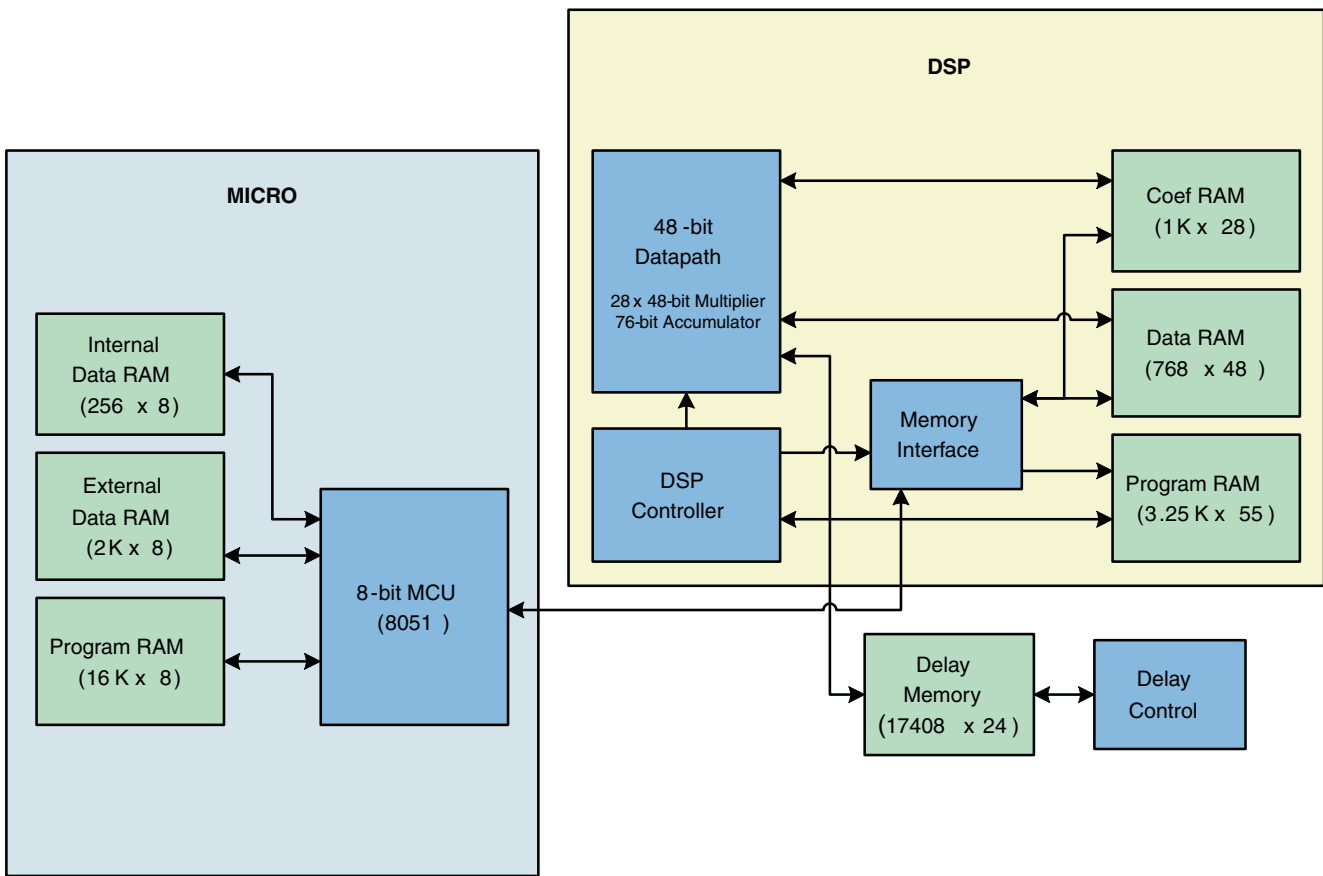

Figure 28. DSP Output Register Configuration



A. Memory size K = 1024

Figure 29. DSP, MCU, and Memory Interfaces

### Delay Memory

The delay memory interface (DMIF) is the interface block between the DSP core and the delay memory. The DMIF block's primary purpose is to keep track of 24 sets of delay memory pointers that are initially set up by the microcontroller through an I<sup>2</sup>C command(s). Eight of the pointers are used to write/retrieve 48-bit data (full-precision intermediate) and the other 16 for 24-bit data (post quantized). Thus, to support 48-bit word reverb delay, two RAM locations must be used.

The key features of the delay memory are:

- 17408 × 24 delay memory locations
- 24 separately addressable pointers
- Programmable Start/Stop address on each pointer
- Pointers capable of accessing 24-bit or 48-bit words
- Single-port access (one pointer access per access cycle)
- Access cycle < four DSP clocks
- Self clearing – INIT pin used to clear all memory to zero
- Fully synchronous
- DP1–DP15: 16 24-bit pointers
- RP1–RP8: Eight 48-bit (full precision) pointers

Since all of the pointers are contiguous, it is only necessary to write the address END point. For example, if DP1 is to be a three-sample delay, the register DP1 should be set to 0x003. If RP1 is to be a three-sample delay, the register RP1 should be set to the value of DP15 + 6. All of the DP16–DP1 and RP8–RP1 registers must be set to a minimum of a one sample delay (one or two words).

DP1 Start address is defined as 000x0.

DP2 Start address is equal to DP1 end address + 1.

RP1 Start address is equal to DP16 end address + 1.

RP8 Start address is equal to RP7 end address + 2.

Since the Start/Stop address for each pointer is programmable anywhere in the delay RAM's address space, the delay for any one channel can be anywhere in the delay RAM. There is, however, no address space collision avoidance logic to separate the pointers. The user (or micro) must take care to avoid overlapping the address spacing of each pointer.

Pointer register address endpoint registers DP16–DP1 and RP8–RP1 are typically written only during the initialization (fast load) mode of the device. Writing to these registers while the TAS3208 DSP core is accessing the pointers may cause the pointers to cross the address space of another pointer.

To write to the delay RAM, the TAS3208 DSP core controller must present the data to be written on the PT\_DATA bus (LSB always in bit zero of the bus), select the pointer to be accessed by driving the PT\_SEL pins, and assert the PT\_WZ pin for a minimum of four clocks. The pointer will not increment until a write has been performed and the PT\_WZ pin has been deasserted.

To perform a read, the PT\_OUT bus may be read four clocks after PT\_SEL is driven.

### DSP Instruction Word

TAS3208 has a 55-bit instruction word. Each instruction has five independent operations, which can load two operands from data memory and coefficient memory, store the result into data or coefficient memory, and perform two parallel arithmetic operations.

55-BIT INSTRUCTION								
Ext	ALU First Stage	ALU Second Stage	Data Memory Load		Coefficient Memory Load		Memory Store	
0	P1OP	P2OP	MOP1	AD1	MOP2	AD2	MOP3	AD3
54	53–49	48–42	41–37	36–27	26–24	23–14	13–10	9–0

**Figure 30. Instruction Word**

The TAS3208 instruction set is a superset of the TAS3208 instruction set, extending the DSP processing capabilities for improved efficiency of FIR operations, as well as extending the addressable memory space. The Ext instruction bit (bit 54) has been added to extend the internal memory address space by one bit, increasing the memory space from 1K to 2K words.

The superset instruction word maintains backward compatibility with the 54-bit instruction word of the TAS3208 device, since the 54-bit instruction word required dummy storage of two bits in the EEPROM.

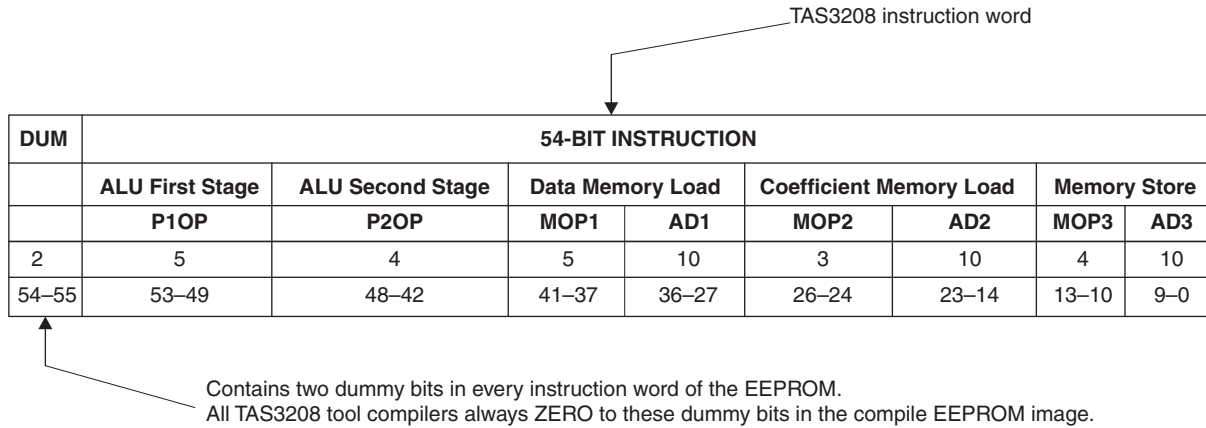

Figure 31. Instruction Word

As shown in Figure 32, the extension bit designates an offset of 1K to all three addresses in the instruction word. However, it should be noted that both data and coefficient memory addresses above the 1K boundary are reserved for housekeeping processing tasks. Any attempt to write to these addresses may corrupt the audio output.

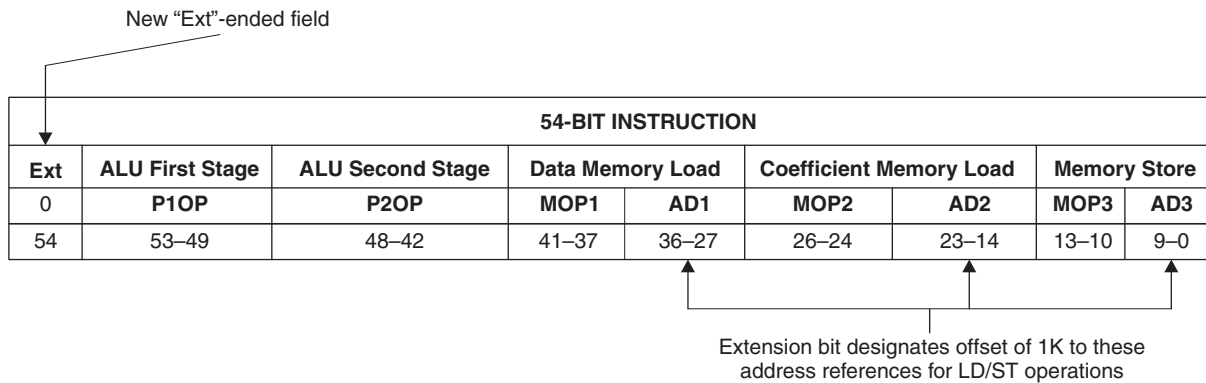

Figure 32. Instruction Word Extension Field

DSP Instruction Set

Please see the *TASxxx Programmer’s Guide* for detailed information regarding programming of this device.



**ABSOLUTE MAXIMUM RATINGS<sup>(1)</sup>**

		MIN	MAX	UNIT
DVDD	Supply voltage range	-0.5	3.8	V
AVDD	Supply voltage range	-0.5	3.8	V
V <sub>I</sub>	Input voltage range	3.3-V TTL	V <sub>DD</sub> + 0.5	V
		3.3-V analog	AV <sub>DD</sub> + 0.5	
		1.8-V LVCMOS	AV <sub>DD</sub> <sup>(2)</sup> + 0.5	
V <sub>O</sub>	Output voltage range	3.3-V TTL	V <sub>DD</sub> + 0.5	V
		3.3-V analog	AV <sub>DD</sub> + 0.5	
		1.8-V LVCMOS	DV <sub>DD</sub> <sup>(3)</sup> + 0.5	
			AV <sub>DD</sub> <sup>(4)</sup> + 0.5	
I <sub>IK</sub>	Input clamp current (V <sub>I</sub> < 0 or V <sub>I</sub> > DV <sub>DD</sub> )		±20	mA
I <sub>OK</sub>	Output clamp current (V <sub>O</sub> < 0 or V <sub>O</sub> > DV <sub>DD</sub> )		±20	mA
T <sub>stg</sub>	Storage temperature range	-65	150	°C
	Lead temperature 1.6 mm (1/16 in) from case for 10 s		260	°C

- Stresses beyond those listed under Absolute Maximum Ratings may cause permanent damage to the device. These are stress ratings only, and functional operation of the device at these or any other conditions beyond those indicated under Recommended Operating Conditions is not implied. Exposure to absolute-maximum-rated conditions for extended periods may affect device reliability.
- AV<sub>DD</sub> is an internal 1.8-V supply derived from a regulator in the TAS3208 chip. Pin XTAL1 is the only TAS3208 input that is referenced to this 1.8-V logic supply. The absolute maximum rating listed is for reference; only a crystal should be connected to XTAL1.
- DV<sub>DD</sub> is an internal 1.8-V supply derived from regulators in the TAS3208 chip. DV<sub>DD</sub> is routed to DV<sub>DD</sub>\_BYPASS\_CAP to provide access to external filter capacitors, but should not be used to source power to external devices.
- Pin XTAL0 is the only TAS3208 output that is derived from the internal 1.8-V logic supply AV<sub>DD</sub>. The absolute maximum rating listed is for reference; only a crystal should be connected to XTAL0. AV<sub>DD</sub> is also routed to AV<sub>DD</sub>\_BYPASS\_CAP to provide access to external filter capacitors, but should not be used to source power to external devices.

**PACKAGE DISSIPATION RATINGS<sup>(1)(2)</sup>**

PACKAGE	T <sub>A</sub> ≤ 25°C POWER RATING	DERATING FACTOR ABOVE T <sub>A</sub> = 25°C	T <sub>A</sub> = 70°C POWER RATING
TQFP – PZP	2.78 W	28.7°C/W	1.22 W

- High-K Board, 105°C junction
- Refer to the application report *PowerPAD™ Thermally Enhanced Package* (literature number [SLMA002](#))

**RECOMMENDED OPERATING CONDITIONS**

		MIN	NOM	MAX	UNIT
DVDD	Digital supply voltage	3	3.3	3.6	V
AVDD	Analog supply voltage	3.3-V analog	3	3.3	3.6
					V
V <sub>IH</sub>	High-level input voltage	3.3-V TTL	2		V
		1.8-V LVCMOS (XTL_IN)	1.26	1.95	
V <sub>IL</sub>	Low-level input voltage	3.3-V TTL		0.8	V
		1.8-V LVCMOS (XTL_IN)		0.54	
T <sub>A</sub>	Operating ambient air temperature (ensuring parametric)	-20	25	70	°C
T <sub>J</sub>	Operating junction temperature	-20		105	°C

## AUDIO SPECIFICATIONS – CHANNEL (INPUT TO OUTPUT)

$T_A = 25^\circ\text{C}$ ,  $AVDD = 3.3\text{ V}$ ,  $DVDD = 3.3\text{ V}$ ,  $F_s$  (audio) = 48 kHz, clock source from XTALI, AES17 filter, second-order 30-kHz low-pass filter (unless otherwise noted)

PARAMETER		CONDITIONS	MIN	TYP	MAX	UNIT
Overall dynamic range	A-in → ADC → DSP → DAC → Lineout	A: WTD	87	92		dB
	A-in → MUX → Lineout	A-WTD	95	98		

## AUDIO SPECIFICATIONS – DIGITAL FILTERS

$T_A = 25^\circ\text{C}$ ,  $AVDD = 3.3\text{ V}$ ,  $DVDD = 3.3\text{ V}$ ,  $F_s$  (audio) = 48 kHz, clock source from XTALI, AES17 filter, second-order 30-kHz low-pass filter (unless otherwise noted)

PARAMETER	MIN	TYP	MAX	UNIT
<b>ADC Decimation Filter, <math>F_s = 48\text{ kHz}</math></b>				
Filter gain from 0 $F_s$ to 0.39 $F_s$		$\pm 0.1$		dB
Filter gain at 0.4125 $F_s$		-0.25		dB
Filter gain at 0.45 $F_s$		-3		dB
Filter gain at 0.5 $F_s$		-17.5		dB
Filter gain from 0.55 $F_s$ to 64 $F_s$		-75		dB
Filter group delay		17/ $F_s$		s
<b>DAC Interpolation Filter, <math>F_s = 48\text{ kHz}</math></b>				
Pass band	20		$0.45 \times F_s$	Hz
Pass-band ripple		$\pm 0.06$		dB
Transition band	$0.45 \times F_s$		$0.5501 \times F_s$	Hz
Stop band	$0.5501 \times F_s$		$7.455 \times F_s$	kHz
Stop-band attenuation		-65		dB
Filter group delay		21/ $F_s$		s

**ELECTRICAL SPECIFICATIONS – ANALOG SECTIONS<sup>(1)</sup>**

$T_A = 25^\circ\text{C}$ ,  $AVDD = 3.3\text{ V}$ ,  $DVDD = 3.3\text{ V}$ ,  $F_s$  (audio) = 48 kHz, clock source from XTALI, AES17 filter, second-order 30-kHz low-pass filter (unless otherwise noted)

PARAMETER	TEST CONDITIONS	MIN	TYP	MAX	UNIT
<b>Stereo MUX Input/ADC Channel</b>	1-kHz sine-wave input				
Full-scale input voltage (0 dB)			1	1.15	Vrms
Input common-mode voltage	Over recommended operating conditions	1.43	1.5	1.57	V
DNR	–60-dB full-scale input applied at line inputs, A-weighted	90	93		dBA
THD + N	1-kHz, –4-dB full-scale input	–75	–80		dB
PSRR	1 kHz, 100 mVpp on AVDD	51	57		dB
Channel separation	1 kHz	–80	–90		dB
Input resistance		14.6	18.33	22	k $\Omega$
Input capacitance			10		pF
<b>DAC Channel/DAC Output</b>	1-kHz sine-wave input, Load = 10 k $\Omega$ , 10 pF				
Full-scale output voltage (0 dB)		0.81	0.9		Vrms
Gain error		–10		10	%
Output common mode	Over recommended operating conditions	1.43	1.5	1.57	V
DNR	–60-dB full-scale input applied at line inputs, A-weighted	95	97		dBA
THD + N	–1-dBFS input, 0-dB gain	–80	–90		dB
PSRR	1 kHz, 100 mVpp on AVDD, $V_{GND}$ powered down	50	56		dB
Load capacitance					pF
Load resistance		10			k $\Omega$
Channel separation		–81	–84		dB
<b>DAC Channel/ Headphone Output</b>	1-kHz sine-wave input, Load = 16 $\Omega$ , External series resistance = 16 $\Omega$ , Coupling capacitance = 47 $\mu\text{F}$				
Full-scale output voltage (0 dB)		0.72	0.9		Vrms
DNR	–60-dB full-scale input applied at Line inputs, A-weighted	80	90		dBA
THD + N	0-dBFS input, 0-dB gain	–50	–60		dB
PSRR	1 kHz, 100 mVpp on AVDD, $V_{GND}$ powered down	48	54		dB
Maximum output power <sup>(2)</sup>			24		mW
Load capacitance				100	pF
Load resistance		16			$\Omega$
Channel separation		–70	–80		dB

(1) When the TAS3208 is operated in slave mode, the internal analog clocks for ADC and DAC are derived from external MCLKIN input. In this case, the analog performance will depend on MCLKIN quality (i.e., jitter, phase noise, etc.).

(2) 16- $\Omega$  series resistor required in L and R headphone outputs for short-circuit protection.

**ELECTRICAL SPECIFICATIONS – ANALOG SECTIONS (continued)**

$T_A = 25^\circ\text{C}$ ,  $AVDD = 3.3\text{ V}$ ,  $DVDD = 3.3\text{ V}$ ,  $F_s$  (audio) = 48 kHz, clock source from XTALI, AES17 filter, second-order 30-kHz low-pass filter (unless otherwise noted)

PARAMETER	TEST CONDITIONS	MIN	TYP	MAX	UNIT
<b>DAC Channel/Headphone Output</b>	1-kHz sine-wave input, Load = 10 k $\Omega$ , 10 pF				
Full-scale output voltage (0 dB)		0.81	0.9		Vrms
DNR	–60-dB full-scale input applied at line inputs, A-weighted	80	90		dBA
THD + N	0-dBFS input, 0-dB gain	–70	–82		dB
PSRR	1 kHz, 100 mVpp on AVDD, $V_{GND}$ powered down	48	54		dB
Channel separation		–70	–80		dB
<b>Analog Mux in Bypass Mode</b>	1-kHz sine-wave input, Load = 10 k $\Omega$ , 10 pF				
Mux switching noise	LINEIN inputs floating	–20		20	mV
Full-scale input voltage (0 dB)			1	1.15	Vrms
Input common-mode voltage		1.43	1.5	1.57	V
Load capacitance				20	pF
Load resistance		10			k $\Omega$
Channel separation	Between Lch and Rch		–80		dB
	Between each line input		–80		dB
Full-scale output voltage (0 dB)		0.9	1	1.1	Vrms

## ELECTRICAL CHARACTERISTICS

over recommended operating conditions (unless otherwise noted)

PARAMETER		TEST CONDITIONS	MIN	MAX	UNIT
V <sub>OH</sub>	High-level output voltage	3.3-V TTL		2.4	V
		1.8-V LVCMOS (XTL_OUT)	I <sub>OH</sub> = -4 mA	1.44	
V <sub>OL</sub>	Low-level output voltage	3.3-V TTL	I <sub>OL</sub> = 4 mA	0.5	V
		1.8-V LVCMOS (XTL_OUT)	I <sub>OL</sub> = 0.75 mA	0.396	
I <sub>OZ</sub>	High-impedance output current	3.3-V TTL		±20	μA
I <sub>IL</sub>	Low-level input current <sup>(1)</sup>	1.8-V LVCMOS (XTL_IN)	V <sub>I</sub> = V <sub>IL</sub>	±1	μA
		3.3-V TTL		±1	
I <sub>IH</sub>	High-level input current <sup>(2)</sup>	1.8-V LVCMOS (XTL_IN)	V <sub>I</sub> = V <sub>IH</sub>	±1	μA
		3.3-V TTL		±1	
I <sub>DVDD</sub>	Digital supply current	DSP clock = 135 MHz, LRCLKIN/LRCLKOUT = 48 KHz, XTALI = 24.288 MHz		200	mA
I <sub>AVDD</sub>	Analog supply current	DSP clock = 135 MHz, LRCLKIN/LRCLKOUT = 48 KHz, XTALI = 24.288 MHz		28	mA
I <sub>DVDD</sub>	Digital supply current	RESET = LOW		0.1	mA
I <sub>AVDD</sub>	Analog supply current	RESET = LOW		5	mA

(1) Value given is for those input pins that connect to an internal pullup resistor, as well as an input buffer. For inputs that have a pulldown resistor or no resistor, I<sub>IL</sub> = ±1 μA.

(2) Value given is for those input pins that connect to an internal pulldown resistor, as well as an input buffer. For inputs that have a pullup resistor or no resistor, I<sub>IH</sub> = ±1 μA.

## TIMING REQUIREMENTS – MASTER CLOCK SIGNALS

 over recommended operating conditions (see [Figure 33](#))

		MIN	TYP	MAX	UNIT
f <sub>XTALI</sub>	XTALI frequency (1/ t <sub>cyc1</sub> ) <sup>(1)</sup>		24.576 (512 Fs)		MHz
t <sub>cyc1</sub>	XTALI cycle time <sup>(2)</sup>		1/(512 Fs)		ns
f <sub>MCLKIN</sub>	MCLKIN frequency (1/ t <sub>cyc2</sub> )		256 Fs		MHz
t <sub>wMCLKIN</sub>	MCLKIN pulse duration <sup>(3)</sup>	0.4 × t <sub>cyc2</sub>		0.6 × t <sub>cyc2</sub>	ns
f <sub>MCLKOUT</sub>	MCLKOUT frequency(1/ t <sub>cyc3</sub> )		256 Fs		MHz
t <sub>rMCLKOUT</sub>	MCLKOUT rise time	C <sub>L</sub> = 30 pF		10	ns
t <sub>fMCLKOUT</sub>	MCLKOUT fall time	C <sub>L</sub> = 30 pF		10	ns
t <sub>wMCLKOUT</sub>	MCLKOUT pulse duration <sup>(4)</sup>	0.4 × t <sub>cyc3</sub>		0.6 × t <sub>cyc3</sub>	ns
	MCLKOUT jitter	XTALI master clock source	80		ps
t <sub>dMI-MO</sub>	Delay time, MCLKIN rising edge to MCLKOUT rising edge <sup>(5)</sup>	MCLKOUT = MCLKIN		17	ns

(1) Frequency tolerance is ±100 ppm (or better) at 25°C.

(2) t<sub>cyc1</sub> = 1/ f<sub>XTALI</sub>

(3) t<sub>cyc2</sub> = 1/ f<sub>MCLKIN</sub>

(4) t<sub>cyc3</sub> = 1/ f<sub>MCLKOUT</sub>

(5) When MCLKOUT is derived from MCLKIN, MCLKOUT jitter = MCLKIN jitter. MCLKOUT has the same duty cycle as MCLKIN when MCLKOUT = MCLKIN.

## TIMING REQUIREMENTS – RESET

 with respect to DVDD power good (see [Figure 34](#))

		MIN	MAX	UNIT
t <sub>pgw(L)</sub>	Minimum pulse duration, RESET low following DVDD = 3.3 V	100		ms

## TIMING REQUIREMENTS – RESET

control signal parameters over recommended operating conditions (unless otherwise noted) (see [Figure 35](#))

		MIN	TYP	MAX	UNIT
$t_{rDMSTATE}$	Time to outputs inactive		100		$\mu$ s
$t_{wRESET}$	Pulse duration, $\overline{RESET}$ active	200			ns
$t_{rEMSTATE}$	Time to enable I <sup>2</sup> C		<50		ms

## TIMING REQUIREMENTS – SERIAL AUDIO PORT SLAVE MODE

over recommended operating conditions (unless otherwise noted) (see [Figure 36](#))

		MIN	TYP	MAX	UNIT
$f_{LRCLK}$	Frequency, LRCLKIN (FS)	32		48	kHz
$t_{wSCLKIN}$	Pulse duration, SCLKIN high <sup>(1)</sup>	$0.4 \times t_{cyc}$		$0.6 \times t_{cyc}$	ns
$f_{SCLKIN}$	Frequency, SCLKIN		64 Fs		MHz
$t_{cyc}$	Cycle time, SCLKIN <sup>(1)</sup>			1/64 Fs	ns
$t_{pd1}$	Propagation delay, SCLKIN falling edge to SDOOUT			16	ns
$t_{su1}$	Setup time, LRCLK to SCLKIN rising edge	10			ns
$t_{h1}$	Hold time, LRCLK from SCLKIN rising edge	5			ns
$t_{su2}$	Setup time, SDIN to SCLKIN rising edge	10			ns
$t_{h2}$	Hold time, SDIN from SCLKIN rising edge	5			ns
$t_{pd2}$	Propagation delay, SCLKIN falling edge to SCLKOUT falling edge		SCLKOUT = SCLKIN	15	ns

(1)  $t_{cyc} = 1 / f_{SCLKIN}$

## TIMING REQUIREMENTS – SERIAL AUDIO PORT MASTER MODE

over recommended operating conditions (unless otherwise noted) (see [Figure 37](#))

			MIN	TYP	MAX	UNIT
$f_{LRCLK}$	Frequency, LRCLKOUT			48		kHz
$t_{rLRCLK}$	Rise time, LRCLKOUT	$C_L = 30$ pF			12	ns
$t_{fLRCLK}$	Fall time, LRCLKOUT	$C_L = 30$ pF			12	ns
$f_{SCLKOUT}$	Frequency, SCLKOUT <sup>(1)</sup>			64 Fs		MHz
$t_{rSCLKOUT}$	Rise time, SCLKOUT	$C_L = 30$ pF			12	ns
$t_{fSCLKOUT}$	Fall time, SCLKOUT	$C_L = 30$ pF			12	ns
$t_{pd1}$	Propagation delay, SCLKOUT falling edge to LRCLKOUT edge				5	ns
$t_{pd2}$	Propagation delay, SCLKOUT falling edge to SDOOUT1–2				5	ns
$t_{su}$	Setup time, SDIN to SCLKOUT rising edge		25			ns
$t_h$	Hold time, SDIN from SCLKOUT rising edge		30			ns

(1) Typical duty cycle is 50/50.

## TIMING CHARACTERISTICS – SPDIF INTERFACE

PARAMETER	TEST CONDITIONS	MIN	TYP	MAX	UNIT
$F_s$	Encoded data sampling rate	32		48	kHz
$R_{spdif}$	SPDIF signal bit rate		128 Fs		MHz
UI	Unit interval		$1/R_{spdif}$		ns
$T_{LO}/T_{HI}$	Low/high periods	1 UI		3 UI	ns
$V_{OH}$	High-level output voltage	3.3-V TTL, $I_{OH} = -4$ mA	2.4		V
$V_{OL}$	Low-level output voltage	3.3-V TTL, $I_{OL} = 4$ mA		0.5	V

## I<sup>2</sup>C INTERFACE AND I/O CHARACTERISTICS OF SDA AND SCL BUS LINES FOR STANDARD-MODE AND FAST-MODE I<sup>2</sup>C BUS DEVICES

 See [Figure 38](#)

		STANDARD MODE		FAST MODE		UNIT
		MIN	MAX	MIN	MAX	
f <sub>SCL</sub>	SCL clock frequency	0	100	0	400 <sup>(1)</sup>	kHz
t <sub>HD;STA</sub>	Hold time, (repeated) Start condition. After this period, the first clock pulse is generated.	4		0.6		μs
t <sub>LOW</sub>	LOW period of SCL clock	4.7		1.3		μs
t <sub>HI;GH</sub>	HIGH period of SCL clock	4		0.6		μs
t <sub>SU;STA</sub>	Setup time, repeated Start condition	4.7		0.6		μs
t <sub>SU;DAT</sub>	Data setup time	250		100 <sup>(2)</sup>		ns
t <sub>r</sub>	Rise time, both SDA and SCL signals		1000	20 + 0.1 × C <sub>b</sub> <sup>(3)</sup>	300	ns
t <sub>f</sub>	Fall time, both SDA and SCL signals		300	20 + 0.1 × C <sub>b</sub> <sup>(3)</sup>	300	ns
t <sub>SU;STO</sub>	Setup time, Stop condition	4		0.6		μs
t <sub>BUF</sub>	Bus free time between Stop and Start condition	4.7		1.3		μs
C <sub>b</sub>	Capacitive load for each bus line		400		400	pF
V <sub>nL</sub>	Noise margin at LOW level for each connected device (including hysteresis)	0.1 × V <sub>DD</sub>		0.1 × V <sub>DD</sub>		V
V <sub>nH</sub>	Noise margin at HIGH level for each connected device (including hysteresis)	0.2 × V <sub>DD</sub>		0.2 × V <sub>DD</sub>		V
V <sub>hys</sub>	Hysteresis of Schmitt-trigger inputs			0.05 × V <sub>DD</sub>		V
t <sub>SP</sub>	Pulse width of spikes that must be suppressed by the input filter			0	50	ns
I <sub>i</sub>	Input current each I/O pin with an input voltage between 0.1 × V <sub>DD</sub> and 0.9 × V <sub>DD</sub> max	–10	10	–10 <sup>(4)</sup>	10 <sup>(4)</sup>	μA
C <sub>i</sub>	Capacitance for each I/O pin		10		10	pF
t <sub>of</sub>	Output fall time from V <sub>IH</sub> min to V <sub>IL</sub> max, with a bus capacitance from 10 pF to 400 pF		250 <sup>(5)</sup>	7 + 0.1 × C <sub>b</sub> <sup>(3)</sup>	250 <sup>(5)</sup>	ns

(1) In Master mode, the maximum I<sup>2</sup>C clock rate is 375 kHz.

(2) A Fast-mode I<sup>2</sup>C bus device can be used in a Standard-mode I<sup>2</sup>C bus system, but the requirement t<sub>SU;DAT</sub> ≥ 250 ns must then be met. This will automatically be the case if the device does not stretch the LOW period of the SCL signal. If such a device does stretch the LOW period of the SCL signal, it must output the next data bit to the SDA line.

(3) C<sub>b</sub> = Total capacitance of one bus line in pF

(4) I/O pins of Fast-mode devices must not obstruct the SDA and SCL lines if V<sub>DD</sub> is switched off.

(5) The maximum t<sub>r</sub> for the SDA and SCL bus lines (300 ns) is longer than the specified maximum t<sub>of</sub> for the output stages (250 ns). This allows series protection resistors (R<sub>s</sub>) to be connected between the SDA/SCL pins and the SDA/SCL bus lines, without exceeding the maximum specified t<sub>r</sub>.





PARAMETER MEASUREMENT INFORMATION (continued)

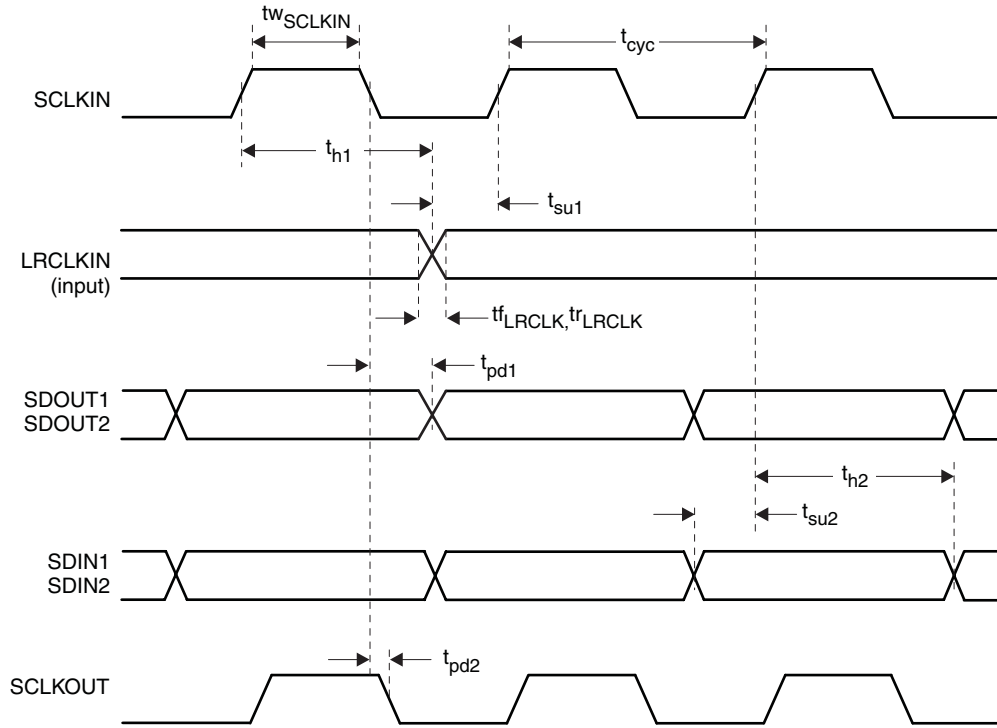

Figure 36. Serial Audio Port Slave-Mode Timing

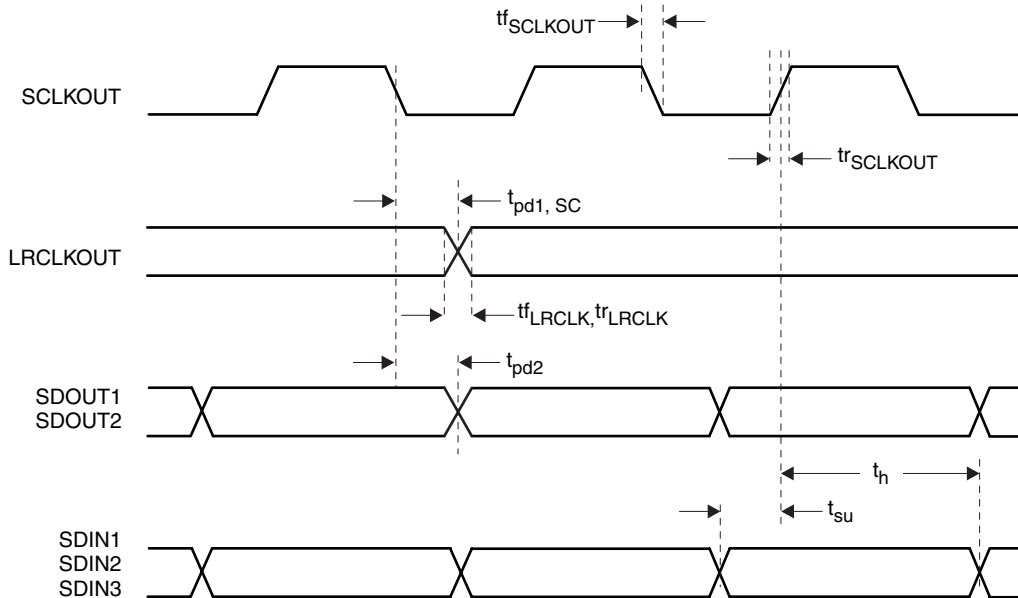

Figure 37. Serial Audio Port Master-Mode Timing

PARAMETER MEASUREMENT INFORMATION (continued)

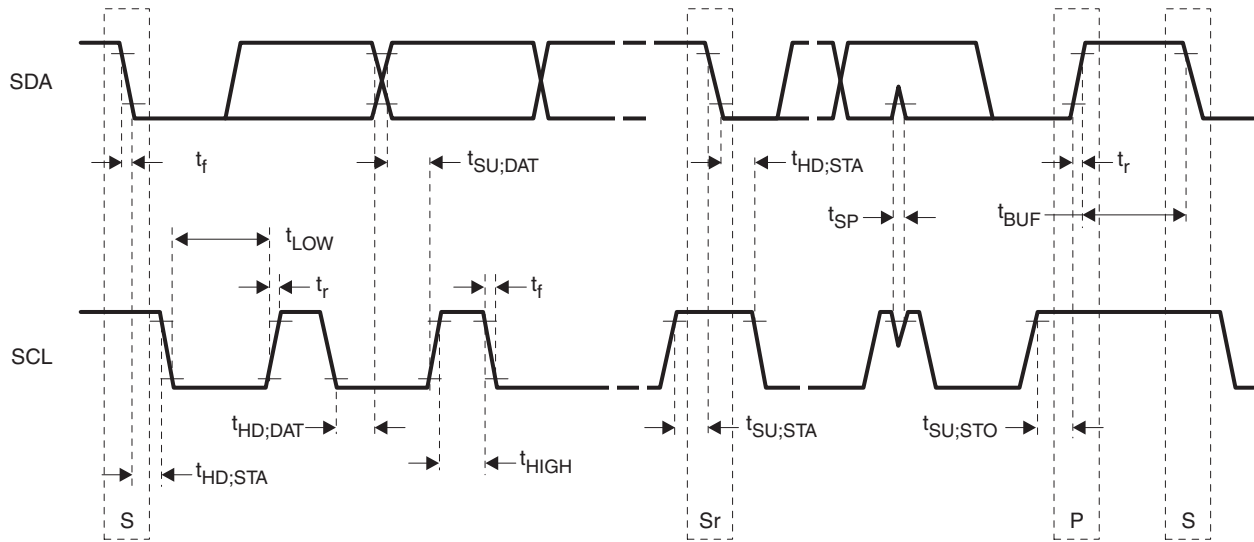

Figure 38. I<sup>2</sup>C SCL and SDA Timing

Master I<sup>2</sup>C Load RAM Block Formats

This section describes the format of the data that is stored in an external memory device and downloaded to the TAS3208 via the master I<sup>2</sup>C bus.

Master I<sup>2</sup>C Memory Block Header

Table 9. 1 Memory Block Header

STARTING BYTE	DATA BLOCK FORMAT	SIZE	NOTES
0	Checksum MSB Checksum LSB	2 bytes	Checksum of byte 2 through N + 12
2	Header ID byte 1 = 0x00 Header ID byte 2 = 0x1F	2 bytes	Must be 0x001F
4	Memory to be loaded	1 byte	0x00: Microprogram RAM or termination header 0x01: Micro external data RAM 0x02: DSP program RAM 0x03 : DSP coefficient RAM 0x04: DSP data RAM 0x05–0x0F: Reserved
5	0x00	1 byte	Unused
6	Start memory address MSB Start memory address LSB	2 bytes	If this is a termination header, this value is 0000.
8	Total number of byte transferred MSB Total number of byte transferred LSB	2 bytes	Header size (12) + data byte + last checksum byte. If this is a termination header, this value is 0000.
10	0x00	1 byte	Unused
11	0x00	1 byte	Unused

**Master I<sup>2</sup>C Download Memory Block Structure**
**Table 10. 1 M8051 MCU Program RAM and External Data RAM Block Structure**

STARTING BYTE	DATA BLOCK FORMAT	SIZE	VALUE	NOTES
0	Checksum MSB	2 bytes		Checksum of byte 2 through N + 12
	Checksum LSB			
2	Header ID byte 1	2 bytes	0x00	Must be 0x001F
	Header ID byte 2		0x1F	
4	Memory to be loaded	1 byte	0x00 or 0x01	Microprogram RAM or micro external data RAM
5	0x00	1 byte	0x00	Unused
6	Start memory address MSB	2 bytes		If this is a termination header, this value is 0000
	Start memory address LSB			
8	Total number of byte transferred MSB	2 bytes		Header (12) + data (N) + checksum (4)
	Total number of byte transferred LSB			
10	0x00	1 byte	0x00	Unused
11	0x00	1 byte	0x00	Unused
12	Data byte 1 (LSB)	4 bytes		1–4 microprocessor byte
	Data byte 2			
	Data byte 3			
	Data byte 4 (MSB)			
16	Data byte 5 (LSB)	4 bytes		5–8 microprocessor byte
	Data byte 6			
	Data byte 7			
	Data byte 8 (MSB)			
•	•	•	•	•
•	•	•	•	•
•	•	•	•	•
N + 12	0x00	4 bytes		Repeated checksum byte 2 through N + 11
	0x00			
	Checksum MSB			
	Checksum LSB			

**Table 11. DSP Program RAM Block Structure**

STARTING BYTE	DATA BLOCK FORMAT	SIZE	VALUE	NOTES
0	Checksum MSB	2 bytes		Checksum of byte 2 through N + 12
	Checksum LSB			
2	Header ID byte 1	2 bytes	0x00	Must be 0x001F
	Header ID byte 2		0x1F	
4	Memory to be loaded	1 byte	0x02	Microprogram RAM or micro external data RAM
5	0x00	1 byte	0x00	Unused
6	Start memory address MSB	2 bytes		If this is a termination header, this value is 0000.
	Start memory address LSB			
8	Total number of byte transferred MSB	2 bytes		Header (12) + data (N) + checksum (4)
	Total number of byte transferred LSB			
10	0x00	1 byte	0x00	Unused
11	0x00	1 byte	0x00	Unused
12	Program byte 1 (LSB)	7 bytes		Program word 1 D7–D0
	Program byte 2			D15–D8
	Program byte 3			D23–D16
	Program byte 4			D31–D24
	Program byte 5			D39–D32
	Program byte 6			D47–D40
	Program byte 7 (MSB)			D55–D48
19	Program byte 8 (LSB)	7 bytes		Program word 2
	Program byte 9			
	Program byte 10			
	Program byte 11			
	Program byte 12			
	Program byte 13			
	Program byte 14 (MSB)			
•	•	•	•	•
•	•	•	•	•
•	•	•	•	•
N + 12	0x00	7 bytes		Repeated checksum byte 2 through N + 11
	0x00			
	0x00			
	0x00			
	0x00			
	Checksum MSB			
	Checksum LSB			

**Table 12. DSP Coefficient RAM Block Structure**

STARTING BYTE	DATA BLOCK FORMAT	SIZE	VALUE	NOTES
0	Checksum MSB	2 bytes		Checksum of byte 2 through N + 12
	Checksum LSB			
2	Header ID byte 1	2 bytes	0x00	Must be 0x001F
	Header ID byte 2		0x1F	
4	Memory to be loaded	1 byte	0x03	Microprogram RAM or micro external data RAM
5	0x00	1 byte	0x00	Unused
6	Start memory address MSB	2 bytes		If this is a termination header, this value is 0000.
	Start memory address LSB			
8	Total number of byte transferred MSB	2 bytes		Header (12) + data (N) + checksum (4)
	Total number of byte transferred LSB			
10	0x00	1 byte	0x00	Unused
11	0x00	1 byte	0x00	Unused
12	Data byte 1 (LSB)	4 bytes		Coefficient word 1 D7–D0
	Data byte 2			D15–D8
	Data byte 3			D23–D16
	Data byte 4 (MSB)			D31–D24
16	Data byte 5 (LSB)	4 bytes		Coefficient word 2
	Data byte 6			
	Data byte 7			
	Data byte 8 (MSB)			
• • •	• • •	• • •	• • •	• • •
N + 12	0x00	4 bytes		Repeated checksum byte 2 through N + 11
	0x00			
	Checksum MSB			
	Checksum LSB			

**Table 13. DSP Data RAM Block Structure**

STARTING BYTE	DATA BLOCK FORMAT	SIZE	VALUE	NOTES
0	Checksum MSB	2 bytes		Checksum of byte 2 through N + 12
	Checksum LSB			
2	Header ID byte 1	2 bytes	0x00	Must be 0x001F
	Header ID byte 2		0x1F	
4	Memory to be loaded	1 byte	0x04	Microprogram RAM or micro external data RAM
5	0x00	1 byte	0x00	Unused
6	Start memory address MSB	2 bytes		If this is a termination header, this value is 0000.
	Start memory address LSB			
8	Total number of byte transferred MSB	2 bytes		Header (12) + data (N) + checksum (4)
	Total number of byte transferred LSB			
10	0x00	1 byte	0x00	Unused
11	0x00	1 byte	0x00	Unused
12	Data byte 1 (LSB)	6 bytes		Data word 1 D7–D0
	Data byte 2			D15–D8
	Data byte 3			D23–D16
	Data byte 4 (MSB)			D31–D24
	Data byte 5			D39–D32
	Data byte 6 (MSB)			D47–D40
18	Data byte 7 (LSB)	6 bytes		Data word 2
	Data byte 8			
	Data byte 9			
	Data byte 10			
	Data byte 11			
	Data byte 12 (MSB)			
•	•	•	•	•
•	•	•	•	•
•	•	•	•	•
N + 12	0x00	6 bytes		Repeated checksum byte 2 through N +11
	0x00			
	Checksum MSB			
	Checksum LSB			

**Slave I<sup>2</sup>C Load RAM Block Formats**

The slave I<sup>2</sup>C bus permits the system controller to load the TAS3208 memories as an alternative to using the master download from an external memory device via the I<sup>2</sup>C master bus. The transfer is performed by writing to two I<sup>2</sup>C registers (0x04 and 0x05). The first register holds the header information, and the second register holds eight bytes of data. [Figure 39](#) shows the I<sup>2</sup>C slave download flow.

I<sup>2</sup>C slave download register format are described in [Table 14](#) to [Table 18](#). The I<sup>2</sup>C slave download process is terminated when a termination header with zero-length byte count field is received.

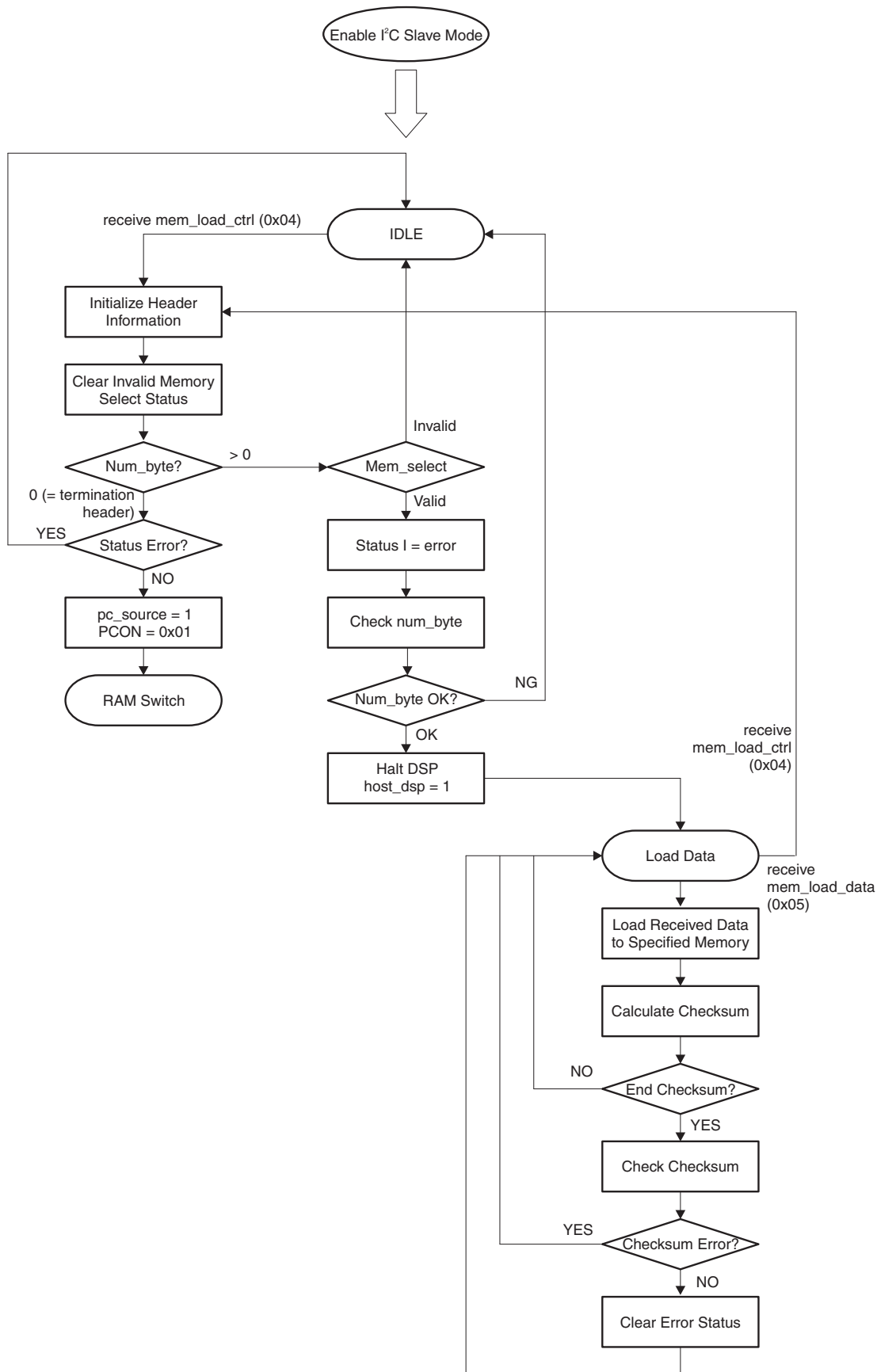

Figure 39. I<sup>2</sup>C Slave Download Flow





**Table 14. M8051 Microcontroller Program RAM and External Data RAM Block Structure<sup>(1)</sup>**

REGISTER	BYTE	DATA BLOCK FORMAT	CALC CHECKSUM	TOTAL NO. BYTES	NOTE
Control 0x04	1	Checksum MSB			
	2	Checksum LSB			
	3	Memory to be loaded 0x00 or 0x01			
	4	0x00			
	5	Start memory address MSB			
	6	Start memory address LSB			
	7	Total number of byte transferred MSB			
	8	Total number of byte transferred LSB			
Data 0x05	1	Datum 1 D7–D0			
	2	Datum 2 D7–D0			
	3	Datum 3 D7–D0			
	4	Datum 4 D7–D0			
	5	Datum 5 D7–D0			
	6	Datum 6 D7–D0			
	7	Datum 7 D7–D0			
	8	Datum 8 D7–D0			
Data 0x05	1	Datum 9 D7–D0			
	2	Datum 10 D7–D0			
	3	Datum 11 D7–D0			
	4	Datum 12 D7–D0			
	5	Datum 13 D7–D0			
	6	Datum 14 D7–D0			
	7	Datum 15 D7–D0			
	8	Datum 16 D7–D0			
Data 0x05	1	Datum N-3 D7–D0			If the last data register datum is less than 6 byte, zero data should be filled.
	2	Datum N-2 D7–D0			
	3	Datum N-1 D7–D0			
	4	Datum N D7–D0			
	5	0x00			Should be zero
	6	0x00			
	7	Checksum MSB			End checksum is always located here.
	8	Checksum LSB			

(1) Shades cells indicate the values included in the checksum/total number of bytes calculation.

**Table 15. DSP Program RAM Block Structure<sup>(1)</sup>**

REGISTER	BYTE	DATA BLOCK FORMAT	CALC CHECKSUM	TOTAL NO. BYTES	NOTE
Control 0x04	1	Checksum MSB			
	2	Checksum LSB			
	3	Memory to be loaded 0x02			
	4	0x00			
	5	Start memory address MSB			
	6	Start memory address LSB			
	7	Total number of byte transferred MSB			
	8	Total number of byte transferred LSB			
Data 0x05	1	0x00			Program word 1
	2	D55–D48			
	3	D47–D40			
	4	D39–D32			
	5	D31–D24			
	6	D23–D16			
	7	D15–D8			
	8	D7–D0			
Data 0x05	1	0x00			Program word 2
	2	D55–D48			
	3	D47–D40			
	4	D39–D32			
	5	D31–D24			
	6	D23–D16			
	7	D15–D8			
	8	D7–D0			
Data 0x05	1	0x00			Should be zero
	2	0x00			
	3	0x00			
	4	0x00			
	5	0x00			
	6	0x00			
	7	Checksum MSB			End checksum is always located here.
	8	Checksum LSB			

(1) Shades cells indicate the values included in the checksum/total number of bytes calculation.

**Table 16. DSP Coefficient RAM Block Structure<sup>(1)</sup>**

REGISTER	BYTE	DATA BLOCK FORMAT	CALC CHECKSUM	TOTAL NO. BYTES	NOTE
Control 0x04	1	Checksum MSB			
	2	Checksum LSB			
	3	Memory to be loaded 0x03			
	4	0x00			
	5	Start memory address MSB			
	6	Start memory address LSB			
	7	Total number of byte transferred MSB			
	8	Total number of byte transferred LSB			
Data 0x05	1	D31–D24			Coefficient word 1
	2	D23–D16			
	3	D15–D8			
	4	D7–D0			
	5	D31–D24			Coefficient word 2
	6	D23–D16			
	7	D15–D8			
	8	D7–D0			
Data 0x05	1	D31–D24			Coefficient word 3
	2	D23–D16			
	3	D15–D8			
	4	D7–D0			
	5	D31–D24			Coefficient word 4
	6	D23–D16			
	7	D15–D8			
	8	D7–D0			
Data 0x05	1	D31–D24			Coefficient word N or zero
	2	D23–D16			
	3	D15–D8			
	4	D7–D0			
	5	0x00			Should be zero
	6	0x00			
	7	Checksum MSB			End checksum is always located here.
	8	Checksum LSB			

(1) Shades cells indicate the values included in the checksum/total number of bytes calculation.

**Table 17. DSP Data Block Structure<sup>(1)</sup>**

REGISTER	BYTE	DATA BLOCK FORMAT	CALC CHECKSUM	TOTAL NO. BYTES	NOTE
Control 0x04	1	Checksum MSB			
	2	Checksum LSB			
	3	Memory to be loaded 0x04			
	4	0x00			
	5	Start memory address MSB			
	6	Start memory address LSB			
	7	Total number of byte transferred MSB			
	8	Total number of byte transferred LSB			
Data 0x05	1	0x00			Coefficient word 1
	2	0x00			
	3	D47–D40			
	4	D39–D32			
	5	D31–D24			Coefficient word 2
	6	D23–D16			
	7	D15–D8			
	8	D7–D0			
Data 0x05	1	0x00			Coefficient word 3
	2	0x00			
	3	D47–D40			
	4	D39–D32			
	5	D31–D24			Coefficient word 4
	6	D23–D16			
	7	D15–D8			
	8	D7–D0			
Data 0x05	1	0x00			Should be zero
	2	0x00			
	3	0x00			
	4	0x00			
	5	0x00			
	6	0x00			
	7	Checksum MSB			End checksum is always located here.
	8	Checksum LSB			

(1) Shades cells indicate the values included in the checksum/total number of bytes calculation.

**Table 18. Termination Header Block Structure<sup>(1)</sup>**

REGISTER	BYTE	DATA BLOCK FORMAT	CALC CHECKSUM	TOTAL NO. BYTES	NOTE
Control 0x04	1	Checksum MSB			00
	2	Checksum LSB			00
	3	Memory to be loaded			00
	4	0x00			00
	5	Start memory address MSB			00
	6	Start memory address LSB			00
	7	Total number of byte transferred MSB			00
	8	Total number of byte transferred LSB			00

(1) Shades cells indicate the values included in the checksum/total number of bytes calculation.

## I<sup>2</sup>C Register Map

The I<sup>2</sup>C register map for ROM advanced code is described in [Table 19](#).

**Table 19. I<sup>2</sup>C Register Map<sup>(1)</sup>**

SUB ADDRESS	REGISTER	BYTES	CONTENTS	DEFAULT VALUE
0x00	SAP/Clock Setting	4	See <a href="#">SAP/Clock Setting Register</a>	
0x01	I <sup>2</sup> C M and N	4	u(31:24), u(23:16), u(15:8), u(7)M(6:3)N(2:0)	0x00, 0x00, 0x00, 0x00
0x02	Status	8	See <a href="#">Status Register</a>	0x00, 0x00, 0x00, 0x00 0x00, 0x00, 0x00, 0x00
0x03	Reserved	4	u(31:24), u(23:16), u(15:8), u(7:0)	0x00, 0x00, 0x00, 0x00
0x04	I <sup>2</sup> C RAM Load Control	8	See <a href="#">I2C RAM Load Control Register</a>	0x00, 0x00, 0x00, 0x00 0x00, 0x00, 0x00, 0x00
0x05	I <sup>2</sup> C RAM Load Data	8	See <a href="#">I2C RAM Load Data Register</a>	0x00, 0x00, 0x00, 0x00 0x00, 0x00, 0x00, 0x00
0x06	PEEK/POKE Control	4	See <a href="#">PEEK/POKE Control Register</a>	0x00, 0x00, 0x00, 0x00
0x07	PEEK/POKE Data	8	See <a href="#">PEEK/POKE Data Register</a>	0x00, 0x00, 0x00, 0x00 0x00, 0x00, 0x00, 0x00
0x08	Silicon Version	4	ver(31:24), ver(23:16), ver(15:8), ver(7:0)	0x00, 0x00, 0x00, 0x02
0x09	Mute Control	4	See <a href="#">Mute Control Register</a>	0x00, 0x00, 0x00, 0x00
0x0a	Reserved	4	u(31:24), u(23:16), u(15:8), u(7:0)	0x00, 0x00, 0x00, 0x00
0x0b	Reserved	4	u(31:24), u(23:16), u(15:8), u(7:0)	0x00, 0x00, 0x00, 0x00
0x0c	GPIO Control	4	See <a href="#">GPIO Control Register</a>	0x00, 0x00, 0x00, 0x00
0x0d	Reserved	4	u(31:24), u(23:16), u(15:8), u(7:0)	0x00, 0x00, 0x00, 0x00
0x0e	Reserved	4	u(31:24), u(23:16), u(15:8), u(7:0)	0x00, 0x00, 0x00, 0x00
0x0f	Reserved	4	u(31:24), u(23:16), u(15:8), u(7:0)	0x00, 0x00, 0x00, 0x00
0x10	Powerdown Control	4	See <a href="#">Powerdown Control Register</a>	0x00, 0x00, 0x00, 0x00
0x11	Reserved	4	u(31:24), u(23:16), u(15:8), u(7:0)	0x00, 0x00, 0x00, 0x00
0x12	A-MUX Control	4	See <a href="#">A-MUX Control Register</a>	0x00, 0x00, 0x00, 0x00
0x13	Reserved	4	u(31:24), u(23:16), u(15:8), u(7:0)	0x00, 0x00, 0x00, 0x00
0x14	Reserved	4	u(31:24), u(23:16), u(15:8), u(7:0)	0x00, 0x00, 0x00, 0x00
0x15	Reserved	4	u(31:24), u(23:16), u(15:8), u(7:0)	0x00, 0x00, 0x00, 0x00

(1) Shades cells indicate common to basic and advanced modes. Unshaded cells indicate advanced mode only.

**Table 19. I<sup>2</sup>C Register Map (continued)**

SUB ADDRESS	REGISTER	BYTES	CONTENTS	DEFAULT VALUE
0x16	SPDIF Control	4	See <a href="#">SPDIF Control Register</a>	0x00, 0x00, 0x00, 0x00
0x17	Reserved	4	u(31:24), u(23:16), u(15:8), u(7:0)	0x00, 0x00, 0x00, 0x00
0x18	Reserved	4	u(31:24), u(23:16), u(15:8), u(7:0)	0x00, 0x00, 0x00, 0x00
0x19	Reserved	4	u(31:24), u(23:16), u(15:8), u(7:0)	0x00, 0x00, 0x00, 0x00
0x1a	Reserved	4	u(31:24), u(23:16), u(15:8), u(7:0)	0x00, 0x00, 0x00, 0x00
0x1b	Reserved	4	u(31:24), u(23:16), u(15:8), u(7:0)	0x00, 0x00, 0x00, 0x00
0x1c	Reserved	8	u(31:24), u(23:16), u(15:8), u(7:0)	0x00, 0x00, 0x00, 0x01 0x47, 0xae, 0x00, 0x00
0x1d	DC Dither	4	See <a href="#">DC Dither Register</a>	0x00, 0x00, 0x00, 0x01
0x1e	DSP Program Start Address	4	See <a href="#">DSP Program Start Address Register</a>	0x00, 0x00, 0x00, 0x00
0x1f	Reserved	4	u(31:24), u(23:16), u(15:8), u(7:0)	0x00, 0x00, 0x00, 0x00
0x20	Unused	4	u(31:24), u(23:16), u(15:8), u(7:0)	0x00, 0x00, 0x00, 0x00
0x21	Unused	4	u(31:24), u(23:16), u(15:8), u(7:0)	0x00, 0x00, 0x00, 0x00
0x22	Unused	4	u(31:24), u(23:16), u(15:8), u(7:0)	0x00, 0x00, 0x00, 0x00
0x23	Unused	4	u(31:24), u(23:16), u(15:8), u(7:0)	0x00, 0x00, 0x00, 0x00
0x24	Unused	4	u(31:24), u(23:16), u(15:8), u(7:0)	0x00, 0x00, 0x00, 0x00
0x25	Unused	4	u(31:24), u(23:16), u(15:8), u(7:0)	0x00, 0x00, 0x00, 0x00
0x26	Unused	4	u(31:24), u(23:16), u(15:8), u(7:0)	0x00, 0x00, 0x00, 0x00
0x27	Unused	4	u(31:24), u(23:16), u(15:8), u(7:0)	0x00, 0x00, 0x00, 0x00
0x28	Unused	4	u(31:24), u(23:16), u(15:8), u(7:0)	0x00, 0x00, 0x00, 0x00
0x29	Unused	4	u(31:24), u(23:16), u(15:8), u(7:0)	0x00, 0x00, 0x00, 0x00
0x2a	Unused	4	u(31:24), u(23:16), u(15:8), u(7:0)	0x00, 0x00, 0x00, 0x00
0x2b	Unused	4	u(31:24), u(23:16), u(15:8), u(7:0)	0x00, 0x00, 0x00, 0x00
0x2c	Unused	4	u(31:24), u(23:16), u(15:8), u(7:0)	0x00, 0x00, 0x00, 0x00
0x2d	Unused	4	u(31:24), u(23:16), u(15:8), u(7:0)	0x00, 0x00, 0x00, 0x00
0x2e	Unused	4	u(31:24), u(23:16), u(15:8), u(7:0)	0x00, 0x00, 0x00, 0x00
0x2f	Unused	4	u(31:24), u(23:16), u(15:8), u(7:0)	0x00, 0x00, 0x00, 0x00
0x30	Unused	4	u(31:24), u(23:16), u(15:8), u(7:0)	0x00, 0x00, 0x00, 0x00
0x31	Unused	4	u(31:24), u(23:16), u(15:8), u(7:0)	0x00, 0x00, 0x00, 0x00
0x32	Unused	16	u(31:24), u(23:16), u(15:8), u(7:0)	0x00, 0x00, 0x00, 0x00
0x33	Unused	16	u(31:24), u(23:16), u(15:8), u(7:0)	0x00, 0x00, 0x00, 0x00
0x34	Unused	16	u(31:24), u(23:16), u(15:8), u(7:0)	0x00, 0x00, 0x00, 0x00
0x35	Unused	16	u(31:24), u(23:16), u(15:8), u(7:0)	0x00, 0x00, 0x00, 0x00
0x36	Unused	16	u(31:24), u(23:16), u(15:8), u(7:0)	0x00, 0x00, 0x00, 0x00
0x37	Unused	16	u(31:24), u(23:16), u(15:8), u(7:0)	0x00, 0x00, 0x00, 0x00
0x38	Unused	16	u(31:24), u(23:16), u(15:8), u(7:0)	0x00, 0x00, 0x00, 0x00
0x39	Unused	16	u(31:24), u(23:16), u(15:8), u(7:0)	0x00, 0x00, 0x00, 0x00
0x3a	Unused	16	u(31:24), u(23:16), u(15:8), u(7:0)	0x00, 0x00, 0x00, 0x00
0x3b	Unused	16	u(31:24), u(23:16), u(15:8), u(7:0)	0x00, 0x00, 0x00, 0x00
0x3c	Unused	16	u(31:24), u(23:16), u(15:8), u(7:0)	0x00, 0x00, 0x00, 0x00
0x3d	Unused	16	u(31:24), u(23:16), u(15:8), u(7:0)	0x00, 0x00, 0x00, 0x00
0xfe	Unused	16	u(31:24), u(23:16), u(15:8), u(7:0)	0x00, 0x00, 0x00, 0x00
0xff	Unused	16	u(31:24), u(23:16), u(15:8), u(7:0)	0x00, 0x00, 0x00, 0x00

**SAP/Clock Setting Register (0x00)**

The SAP/Clock Setting register is used to configure the device as a clock master/slave, as well as specify the desired format of the digital audio ports. This register is four bytes in length.

**Table 20. SAP/Clock Setting Register**

BIT	31	30	29	28	27	26	25	24	DESCRIPTION
	0	0	0	0	0	0	0		Unused
								CM/S	Clock master/slave select
BIT	23	22	21	20	19	18	17	16	
									Unused
								ON	SAP output normalization
BIT	15	14	13	12	11	10	9	8	
	0								Unused
		OW1	OW0						Digital audio output word size
				0	0				Unused
						IW1	IW0		Digital audio input word size
BIT	7	6	5	4	3	2	1	0	
	0								Unused
		OM1	OM0						Digital audio output format
				0	0				Unused
						IM1	IM0		Digital audio input format

**Table 21. Clock Master/Slave Select<sup>(1)</sup>**

CLOCK MASTER/SLAVE SELECT	CMS
<i>Master</i>	1
<i>Slave</i>	0

(1) Default values are shown in italics.

**Table 22. Digital Audio Port Normalization<sup>(1)</sup>**

DIGITAL AUDIO PORT NORMALIZATION	ON
<i>Enable</i>	1
<i>Disable</i>	0

(1) Default values are shown in italics.

Bits 9–8 (IW1 and IW0) define the data word size for the input SAP. Bits 13–12 (OW1 and OW0) define the data word size for the output SAP.

**Table 23. Audio Data Word Size<sup>(1)</sup>**

DIGITAL AUDIO I/O WORD SIZE	IW1/OW1	IW0/OW0
16 bit	0	0
20 bit	0	1
<i>24 bit</i>	1	0
–	1	1

(1) Default values are shown in italics.

**Table 24. Audio Data Format<sup>(1)</sup>**

DIGITAL AUDIO I/O FORMAT	IM1/OM1	IM0/OM0
Left-justified	0	0
Right-justified	0	1
<i>ℒS</i>	<i>1</i>	<i>0</i>
–	1	1

(1) Default values are shown in italics.

**Status Register (0x02)**

The Status register provide memory load information. When a memory load error for a particular memory occurs, the memory load error bit for that memory is set to 1. When a memory load is successful for a particular memory, the memory load error bit for that memory is set to 0. The host must check this load status after memory load. The host can clear all load error status by writing 0 to bits D40–D32 of this register.

**Table 25. Status Register**

BIT	63	62	61	60	59	58	57	56	DESCRIPTION
	0	0	0	0	0	0	0	0	Reserved
<b>BIT</b>	<b>55</b>	<b>54</b>	<b>53</b>	<b>52</b>	<b>51</b>	<b>50</b>	<b>49</b>	<b>48</b>	
	0	0	0	0	0	0	0		Reserved
<b>BIT</b>	<b>47</b>	<b>46</b>	<b>45</b>	<b>44</b>	<b>43</b>	<b>42</b>	<b>41</b>	<b>40</b>	
	0	0	0	0	0	0	0	0	Unused
<b>BIT</b>	<b>39</b>	<b>38</b>	<b>37</b>	<b>36</b>	<b>35</b>	<b>34</b>	<b>33</b>	<b>32</b>	
	x	x	x	x	x	x	x	1	M8051 program memory load error
	x	x	x	x	x	x	1	x	M8051 external memory load error
	x	x	x	x	x	1	x	x	DSP program memory load error
	x	x	x	x	1	x	x	x	DSP coefficient memory load error
	x	x	x	1	x	x	x	x	DSP data memory load error
	x	1	x	x	x	x	x	x	Invalid memory select
	1	x	x	x	x	x	x	x	End of load header error
	1	1	1	1	1	1	1	1	No EEPROM
	0	0	0	0	0	0	0	0	No error
<b>BIT</b>	<b>31</b>	<b>30</b>	<b>29</b>	<b>28</b>	<b>27</b>	<b>26</b>	<b>25</b>	<b>24</b>	
	0	0	0	0	0	0	0		Reserved
<b>BIT</b>	<b>23</b>	<b>22</b>	<b>21</b>	<b>20</b>	<b>19</b>	<b>18</b>	<b>17</b>	<b>16</b>	
	0	0	0	0	0	0	0		Reserved
<b>BIT</b>	<b>15</b>	<b>14</b>	<b>13</b>	<b>12</b>	<b>11</b>	<b>10</b>	<b>9</b>	<b>8</b>	
	0								Reserved
<b>BIT</b>	<b>7</b>	<b>6</b>	<b>5</b>	<b>4</b>	<b>3</b>	<b>2</b>	<b>1</b>	<b>0</b>	
	0								Reserved
		ABSY							Analog busy flag
			0						Reserved
				0					Reserved
					0				Reserved
						0			Reserved
							BUSE		I <sup>2</sup> C bus error
								0	Reserved



Bits 40–32 define the memory load error status on EEPROM download and slave download.

**Table 26. Analog Busy<sup>(1)</sup>**

<b>ANALOG BUSY FLAG</b>	<b>ABSY</b>
Analog is busy	1
<i>Analog not busy</i>	<i>0</i>

(1) Default values are shown in italics.

Analog control sequence takes time (maximum approximately 500 ms for headphone power up). This busy flag indicates whether the analog control sequence is running or not.

**Table 27. I<sup>2</sup>C Bus Error<sup>(1)</sup>**

<b>I<sup>2</sup>C BUS ERROR</b>	<b>BUSE</b>
Bus error	1
<i>No bus error</i>	<i>0</i>

(1) Default values are shown in italics.

If an I<sup>2</sup>C bus error occurs, this flag will be set. Only the host microcontroller can clear this flag by writing 0 to this bit. I<sup>2</sup>C bus error status is read from ESFR 0xC5, bit 6, and is cleared by ESFR 0xC7, bit 6.

### I<sup>2</sup>C RAM Load Control and Data Registers (0x04 and 0x05)

The I<sup>2</sup>C memory load port permits the system controller to load the TAS3208 memories as an alternative to having the TAS3208 load its memory from an external EEPROM.

The transfer is performed by writing to two I<sup>2</sup>C registers. The first register is a 8-byte register than holds the checksum, memory to be written, starting address, and number of data bytes to be transferred. The second register holds eight bytes of data.

The memory load operation starts with the first register being set. Then the data is written into the second register using the format shown. After the last data byte is written into the second register, an additional two bytes are written, which constrain the 2-byte checksum. At that point, the transfer is complete and status of the operation is reported in the Status register.

#### NOTE:

Once the microprogram memory has been loaded, further updates to this memory are inhibited until the device is reset.

When the first I<sup>2</sup>C slave download register is written by the system controller, the TAS3208 updates the Status register by setting a error bit to indicate an error for the memory type that is being loaded. This error bit is reset when the operation complete and a valid checksum has been received.

For example, when the microprogram memory is being loaded, the TAS3208 will set a microprogram memory error indication in the Status register at the start of the sequence. When the last byte of the microprogram memory and checksum is received, the TAS3208 will clear the microprogram memory error indication. This enables the TAS3208 to preserve any error status indications that occur as a result of incomplete transfers of data/ checksum error during a series of data and program memory load operations.

The checksum is always contained in the last two bytes of the data block.

The I<sup>2</sup>C slave download is terminated when a termination header with a zero-length byte count field is received.

**Table 28. I<sup>2</sup>C RAM Load Control Register (0x04)**

BYTE	DATA BLOCK FORMAT	SIZE	NOTES
1–2	Checksum code	2 bytes	Checksum of bytes 2 through N + 8. If this is a termination header, this value is 00 00.
3	Memory to be loaded	1 byte	0: Microprogram memory 1: Micro external data memory 2: DSP program memory 3: DSP coefficient memory 4: DSP data memory 5–15: Reserved
4	Unused	1 byte	Reserved
6–7	Starting TAS3208 memory address	2 bytes	If this is a termination header, this value is 00 00.
7–8	Number of data bytes to be transferred	2 bytes	If this is a termination header, this value is 00 00.

**Table 29. I<sup>2</sup>C RAM Load Data Register (0x05)**

BYTE	8-BIT DATA	24-BIT DATA	28-BIT DATA	48-BIT DATA	55-BIT DATA
1	Datum 1 D7–D0		XXXX D27–D24		
2	Datum 2 D7–D0	D23–D16	D23–D16		X D54–D48
3	Datum 3 D7–D0	D15–D8	D15–D8	D47–D40	D47–D40
4	Datum 4 D7–D0	D7–D0	D7–D0	D39–D32	D39–D32
5	Datum 5 D7–D0		XXXX D27–D24	D31–D24	D31–D24
6	Datum 6 D7–D0	D23–D16	D23–D16	D23–D16	D23–D16
7	Datum 7 D7–D0	D15–D8	D15–D8	D15–D8	D15–D8
8	Datum 8 D7–D0	D7–D0	D7–D0	D7–D0	D7–D0

**PEEK/POKE Control and Data Registers (0x06 and 0x07)**

The PEEK/POKE Control (Table 30) and PEEK/POKE Data (Table 31) registers allow the user to access the internal resources of TAS3208. Figure 40 shows the I<sup>2</sup>C transaction for the PEEK/POKE registers.

**Table 30. PEEK/POKE Control Register (0x06)**

BIT	31	30	29	28	27	26	25	24	DESCRIPTION
	0	0	0	0	0	0	0	0	Unused
BIT	23	22	21	20	19	18	17	16	
	0	0	0	0	0	0	0	1	DSP coefficient memory load error
	0	0	0	0	0	0	1	0	DSP data memory load error
	0	0	0	0	0	0	1	1	DSP delay memory
	0	0	0	0	0	1	0	0	M8051 internal data memory
	0	0	0	0	0	1	0	1	M8051 external data memory
	0	0	0	0	0	1	1	0	Extended special function registers
	0	0	0	0	0	1	1	1	M8051 program memory
	0	0	0	0	1	0	0	0	DSP program memory
BIT	15	14	13	12	11	10	9	8	
	0	0	0	0	0	0	0	0	Memory address MSB
BIT	7	6	5	4	3	2	1	0	
	0	0	0	0	0	0	0	0	Memory address LSB

**Table 31. PEEK/POKE Data Register (0x07)**

BIT	63	62	61	60	59	58	57	56	DESCRIPTION
	D63	D62	D61	D60	D59	D58	D57	D56	Data to be read or written
BIT	55	54	53	52	51	50	49	48	
	D55	D54	D53	D52	D51	D50	D49	D48	Data to be read or written
BIT	47	46	45	44	43	42	41	40	
	D47	D46	D45	D44	D43	D42	D41	D40	Data to be read or written
BIT	39	38	37	36	35	34	33	32	
	D39	D38	D37	D36	D35	D34	D33	D32	Data to be read or written
BIT	31	30	29	28	27	26	25	24	
	D31	D30	D29	D28	D27	D26	D25	D24	Data to be read or written
BIT	23	22	21	20	19	18	17	16	
	D23	D22	D21	D20	D19	D18	D17	D16	Data to be read or written
BIT	15	14	13	12	11	10	9	8	
	D15	D14	D13	D12	D11	D10	D9	D8	Data to be read or written
BIT	7	6	5	4	3	2	1	0	
	D7	D6	D5	D4	D3	D2	D1	D0	Data to be read or written

**Memory Select and Address**

S	Slave address + W	ACK	Sub address (0x06)	ACK	00000000	ACK	memory section	ACK	address (MS Byte)	ACK	address (LS Byte)	ACK	P
---	-------------------	-----	--------------------	-----	----------	-----	----------------	-----	-------------------	-----	-------------------	-----	---

**Peek (Read)**

S	Slave address + W	ACK	Sub address (0x07)	ACK	P
---	-------------------	-----	--------------------	-----	---

S	Slave address + W	ACK	D63–D56	ACK	D55–D48	ACK	D47–D40	ACK	D39–D32	ACK	
			D31–D24	ACK	D23–D16	ACK	D15–D8	ACK	D7–D0	NAK	P

**Poke (Write)**

S	Slave address + W	ACK	Sub address (0x07)	ACK	D63–D56	ACK	D55–D48	ACK	D47–D40	ACK	D39–D32	ACK	
					D31–D24	ACK	D23–D16	ACK	D15–D8	ACK	D7–D0	NAK	P

**Figure 40. I<sup>2</sup>C Transaction for PEEK/POKE**

**Mute Control Register (0x09)**

**Table 32. Mute Control Register**

BIT	31	30	29	28	27	26	25	24	DESCRIPTION
	0	0	0	0	0	0	0	0	Unused
BIT	23	22	21	20	19	18	17	16	
	0	0	0	0	0	0	0	0	Unused
BIT	15	14	13	12	11	10	9	8	
	0	0							Unused
			AMX1	AMX0					Analog MUX out (LINEOUT1)
					SD2	SD2			SDOUT2/SPDIFOUT
							SD1	SD1	SDOUT1
BIT	7	6	5	4	3	2	1	0	
	DAC1	DAC1							DAC1
			DAC2	DAC2					DAC2
					DAC3	DAC3			DAC3
							DIT	DIT	DIT

**Table 33. Mute<sup>(1)</sup>**

MUTE	MUTE[1]	MUTE[0]
<i>Hardware controlled</i>	<i>0</i>	<i>0</i>
Force mute off	0	1
Force mute on	1	0

(1) Default values are shown in italics.

**GPIO Control Register (0x0c)**

**Table 34. GPIO Control Register**

BIT	31	30	29	28	27	26	25	24	DESCRIPTION
	WDE								Watchdog timer
		0	0	0					Unused
					IO2				GPIO2 input/output value
						IO1			GPIO1 input/output value
							DIR2		GPIO2 direction
								DIR1	GPIO1 direction
BIT	23	22	21	20	19	18	17	16	
	x	x	x	x	x	x	x	x	GPIOMICROCOUNT MSB
BIT	15	14	13	12	11	10	9	8	
	x	x	x	x	x	x	x	x	GPIOMICROCOUNT LSB
BIT	7	6	5	4	3	2	1	0	
	y	y	y	y	y	y	y	y	GPIO_Sampling_Interval

GPIOMICROCOUNT sets the number of micro clock cycles for Timer 0 interrupt. In Timer 0 interrupt service routine, the watchdog timer is reset if it is enabled. The default value for this counter is 0x5820, which corresponds to a period 1.25 ms.

**Table 35. Watchdog Timer Enable<sup>(1)</sup>**

WATCHDOG TIMER	WDE
Enable	0

(1) Default values are shown in italics.

**Table 35.  
Watchdog Timer  
Enable (continued)**

WATCHDOG TIMER	WDE
<i>Disable</i>	<i>1</i>

**Table 36. GPIO Direction<sup>(1)</sup>**

GPIOx DIRECTION	DIRx
Output	0
Input	1

(1) Default values are shown in italics.

### Powerdown Control Register (0x10)

**Table 37. Powerdown Control Register**

BIT	31	30	29	28	27	26	25	24	DESCRIPTION
	0	0	0	0	0	0	0	0	Unused
BIT	23	22	21	20	19	18	17	16	
	0	0	0	0	0	0	0	0	Unused
BIT	15	14	13	12	11	10	9	8	
	0	0	0	0	0	0	0	0	Unused
BIT	7	6	5	4	3	2	1	0	
	DIT								DIT reset
		DAC 3							DAC3
			DAC 2						DAC2
				DAC 1					DAC1
					ADC				AMUX + AAF + ADC
						0			Unused
							0		Unused
								AMX1	AMUX1 + LineAmp1

**Table 38. Powerdown<sup>(1)</sup>**

POWERDOWN	PD
<i>Powerdown and disable</i>	<i>0</i>
<i>Powerup and enable</i>	<i>1</i>

(1) Default values are shown in italics.

**A-MUX Control Register(0x12)****Table 39. A-MUX Control Register**

BIT	31	30	29	28	27	26	25	24	DESCRIPTION
	x	x	x	x	1	1	1	1	Reserved
	x	x	x	x	1	1	1	0	Reserved
	x	x	x	x	1	1	0	1	Reserved
	x	x	x	x	1	1	0	0	Reserved
	x	x	x	x	1	0	1	1	DAC
	x	x	x	x	1	0	1	0	Analog MUX line 10 select
	x	x	x	x	1	0	0	1	Analog MUX line 9 select
	x	x	x	x	1	0	0	0	Analog MUX line 8 select
	x	x	x	x	0	1	1	1	Analog MUX line 7 select
	x	x	x	x	0	1	1	0	Analog MUX line 6 select
	x	x	x	x	0	1	0	1	Analog MUX line 5 select
	x	x	x	x	0	1	0	0	Analog MUX line 4 select
	x	x	x	x	0	0	1	1	Analog MUX line 3 select
	x	x	x	x	0	0	1	0	Analog MUX line 2 select
	x	x	x	x	0	0	0	1	Analog MUX line 1 select
	0	0	0	0	0	0	0	0	MUTE
BIT	23	22	21	20	19	18	17	16	
	0	0	0	0	0	0	0	0	Unused
BIT	15	14	13	12	11	10	9	8	
	0	0	0	0	0	0	0	0	Unused
BIT	7	6	5	4	3	2	1	0	
	x	x	x	x	1	1	1	1	Reserved
	x	x	x	x	1	1	1	0	Reserved
	x	x	x	x	1	1	0	1	Reserved
	x	x	x	x	1	1	0	0	Reserved
	x	x	x	x	1	0	1	1	DAC
	x	x	x	x	1	0	1	0	Analog MUX line 10 select
	x	x	x	x	1	0	0	1	Analog MUX line 9 select
	x	x	x	x	1	0	0	0	Analog MUX line 8 select
	x	x	x	x	0	1	1	1	Analog MUX line 7 select
	x	x	x	x	0	1	1	0	Analog MUX line 6 select
	x	x	x	x	0	1	0	1	Analog MUX line 5 select
	x	x	x	x	0	1	0	0	Analog MUX line 4 select
	x	x	x	x	0	0	1	1	Analog MUX line 3 select
	x	x	x	x	0	0	1	0	Analog MUX line 2 select
	x	x	x	x	0	0	0	1	Analog MUX line 1 select
	0	0	0	0	0	0	0	0	MUTE

**SPDIF Control Register (0x16)**
**Table 40. SPDIF Control Register**

BIT	31	30	29	28	27	26	25	24	DESCRIPTION
	CP								Copyright flag
		EMP							Pre-emphasis flag
			CLKAC	CLKA C					Clock accuracy
			b28	b29					
					WL3	WL2	WL1	WL0	Sample word length
BIT	23	22	21	20	19	18	17	16	
	SR	SR							Sampling rate
	b24	b25	0	0	0	0	0	0	
			VL						Left-channel validity flag
				VR					Right-channel validity flag
					SRC#	SRC#	SRC#	SRC#	Source channel number
					b19	b18	b17	b16	
BIT	15	14	13	12	11	10	9	8	
	Cat	Cat	Cat	Cat	Cat	Cat	Cat		Category code
	b8	b9	b10	b11	b12	b13	b14	0	
								L	Generation status
BIT	7	6	5	4	3	2	1	0	
	0	0	0	0	0	0			Unused
							MUX1	MUX0	SPDIF MUX

**Table 41. Copyright Flag<sup>(1)</sup>**

COPYRIGHT FLAG	CP
<i>Copy prohibited</i>	0
Copy permitted	1

(1) Default values are shown in italics.

**Table 42. Pre-Emphasis Flag<sup>(1)</sup>**

PRE-EMPHASIS FLAG	EMP
<i>No pre-emphasis</i>	0
50/15 $\mu$ s pre-emphasis	1

(1) Default values are shown in italics.

**Table 43. Sample Word Length**

SAMPLE WORD LENGTH	WLx
24-bit sample word length	0

**Table 44. Sampling Rate**

SAMPLING RATE	b24	b25
48 kHz	0	1

**Table 45. Validity Flag<sup>(1)</sup>**

VALIDITY FLAG	Vx
<i>Valid</i>	<i>0</i>
Not valid	1

(1) Default values are shown in italics.

**Table 46. Channel Source Number**

CHANNEL SOURCE NUMBER	b19	b18	b17	b16
Channel 2	0	0	1	0

**Table 47. Category Code**

CATEGORY CODE	b8	b9	b10	b11	b12	b13	b14
Digital sound processor	0	1	0	1	0	1	0

**Table 48. Generation Status**

GENERATION STATUS	Vx
Gen 1 or higher	0
Original	1

**Table 49. SDOUT/SPDIF MUX<sup>(1)</sup>**

SDOUT/SPDIF MUX	MUX1	MUX2
<i>SDOUT2</i>	<i>0</i>	<i>0</i>
SPDIF Tx	0	1
SPDIF In	1	–

(1) Default values are shown in italics.



**DC Dither Register (0x1d)**
**Table 50. DC Dither Register**

BIT	31	30	29	28	27	26	25	24	DESCRIPTION
	0	0	0	0	0	0	0	0	Unused
BIT	23	22	21	20	19	18	17	16	
	0	0	0	0	0	0	0	0	Unused
BIT	15	14	13	12	11	10	9	8	
	0	0	0	0	0	0	0	0	Unused
BIT	7	6	5	4	3	2	1	0	
	0	0	0	0	0	0	0		Unused
								ON	DC dither enable

**Table 51. DC Dither Enable<sup>(1)</sup>**

DC DITHER ENABLE	ON
Disable	0
<i>Enable</i>	<i>1</i>

(1) Default values are shown in italics.

**DSP Program Start Address Register (0x1e)**

The DSP instruction execution loops each Fs cycle. At the beginning of the Fs cycle, the DSP instruction pointer is set to the starting address specified in the 12 LSBs. The maximum address is the end address of DSP instruction address 3327.

**Table 52. DSP Program Start Address Register**

BIT	31	30	29	28	27	26	25	24	DESCRIPTION
	0	0	0	0	0	0	0	0	Unused
BIT	23	22	21	20	19	18	17	16	
	0	0	0	0	0	0	0	0	Unused
BIT	15	14	13	12	11	10	9	8	
	0	0	0	0	x	x	x	x	Starting address MSB
BIT	7	6	5	4	3	2	1	0	
	x	x	x	x	x	x	x	x	Starting address LSB

APPLICATION INFORMATION

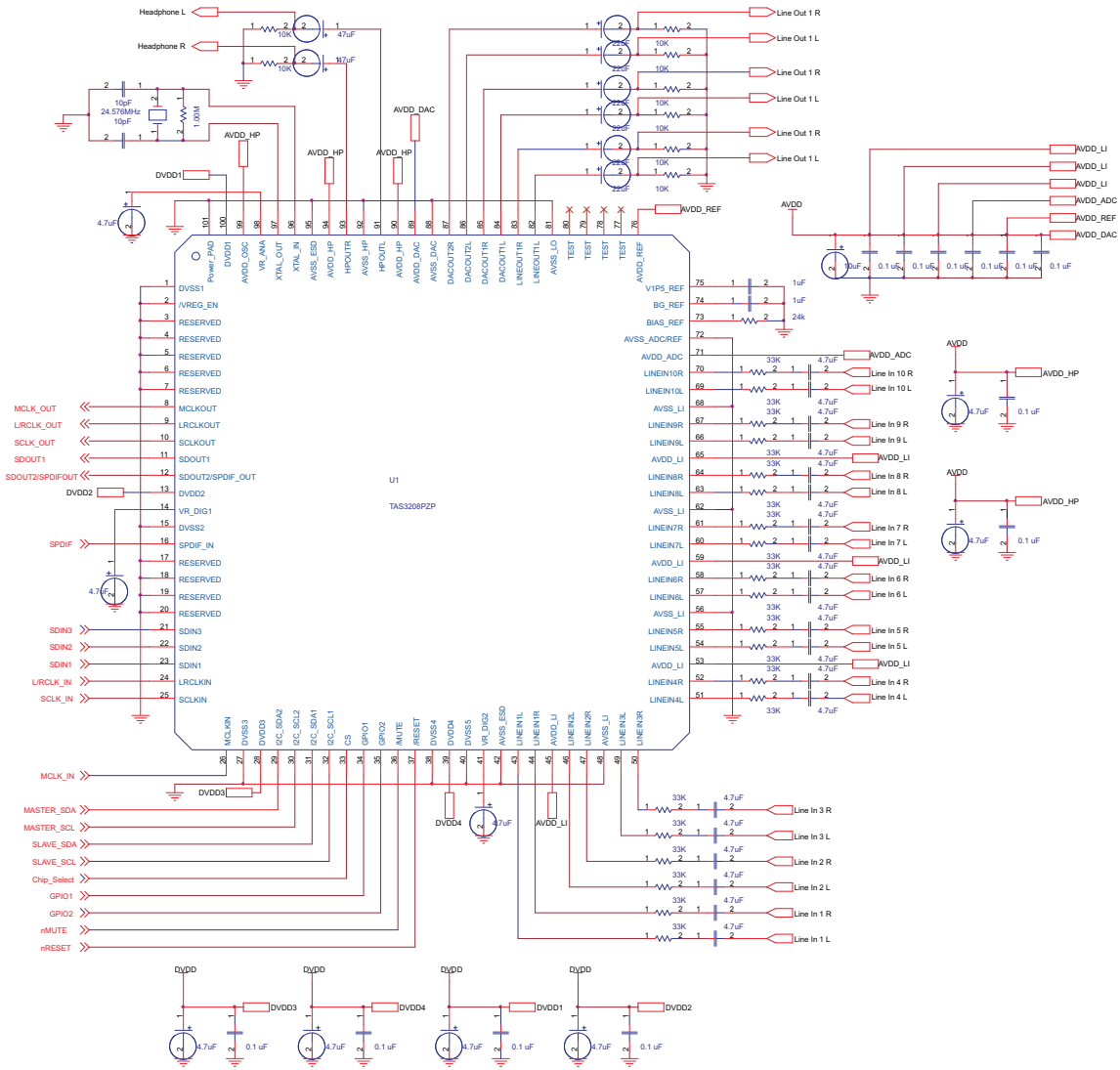

**PACKAGING INFORMATION**

Orderable Device	Status <sup>(1)</sup>	Package Type	Package Drawing	Pins	Package Qty	Eco Plan <sup>(2)</sup>	Lead/Ball Finish	MSL Peak Temp <sup>(3)</sup>
TAS3208IPZP	ACTIVE	HTQFP	PZP	100	90	Green (RoHS & no Sb/Br)	CU NIPDAU	Level-3-260C-168 HR
TAS3208IPZPR	ACTIVE	HTQFP	PZP	100	1000	Green (RoHS & no Sb/Br)	CU NIPDAU	Level-3-260C-168 HR
TAS3208PZP	ACTIVE	HTQFP	PZP	100	90	Green (RoHS & no Sb/Br)	CU NIPDAU	Level-3-260C-168 HR
TAS3208PZPR	ACTIVE	HTQFP	PZP	100	1000	Green (RoHS & no Sb/Br)	CU NIPDAU	Level-3-260C-168 HR

<sup>(1)</sup> The marketing status values are defined as follows:

**ACTIVE:** Product device recommended for new designs.

**LIFEBUY:** TI has announced that the device will be discontinued, and a lifetime-buy period is in effect.

**NRND:** Not recommended for new designs. Device is in production to support existing customers, but TI does not recommend using this part in a new design.

**PREVIEW:** Device has been announced but is not in production. Samples may or may not be available.

**OBSOLETE:** TI has discontinued the production of the device.

<sup>(2)</sup> Eco Plan - The planned eco-friendly classification: Pb-Free (RoHS), Pb-Free (RoHS Exempt), or Green (RoHS & no Sb/Br) - please check <http://www.ti.com/productcontent> for the latest availability information and additional product content details.

**TBD:** The Pb-Free/Green conversion plan has not been defined.

**Pb-Free (RoHS):** TI's terms "Lead-Free" or "Pb-Free" mean semiconductor products that are compatible with the current RoHS requirements for all 6 substances, including the requirement that lead not exceed 0.1% by weight in homogeneous materials. Where designed to be soldered at high temperatures, TI Pb-Free products are suitable for use in specified lead-free processes.

**Pb-Free (RoHS Exempt):** This component has a RoHS exemption for either 1) lead-based flip-chip solder bumps used between the die and package, or 2) lead-based die adhesive used between the die and leadframe. The component is otherwise considered Pb-Free (RoHS compatible) as defined above.

**Green (RoHS & no Sb/Br):** TI defines "Green" to mean Pb-Free (RoHS compatible), and free of Bromine (Br) and Antimony (Sb) based flame retardants (Br or Sb do not exceed 0.1% by weight in homogeneous material)

<sup>(3)</sup> MSL, Peak Temp. -- The Moisture Sensitivity Level rating according to the JEDEC industry standard classifications, and peak solder temperature.

**Important Information and Disclaimer:**The information provided on this page represents TI's knowledge and belief as of the date that it is provided. TI bases its knowledge and belief on information provided by third parties, and makes no representation or warranty as to the accuracy of such information. Efforts are underway to better integrate information from third parties. TI has taken and continues to take reasonable steps to provide representative and accurate information but may not have conducted destructive testing or chemical analysis on incoming materials and chemicals. TI and TI suppliers consider certain information to be proprietary, and thus CAS numbers and other limited information may not be available for release.

In no event shall TI's liability arising out of such information exceed the total purchase price of the TI part(s) at issue in this document sold by TI to Customer on an annual basis.

PZP (S-PQFP-G100)

PowerPAD™ PLASTIC QUAD FLATPACK

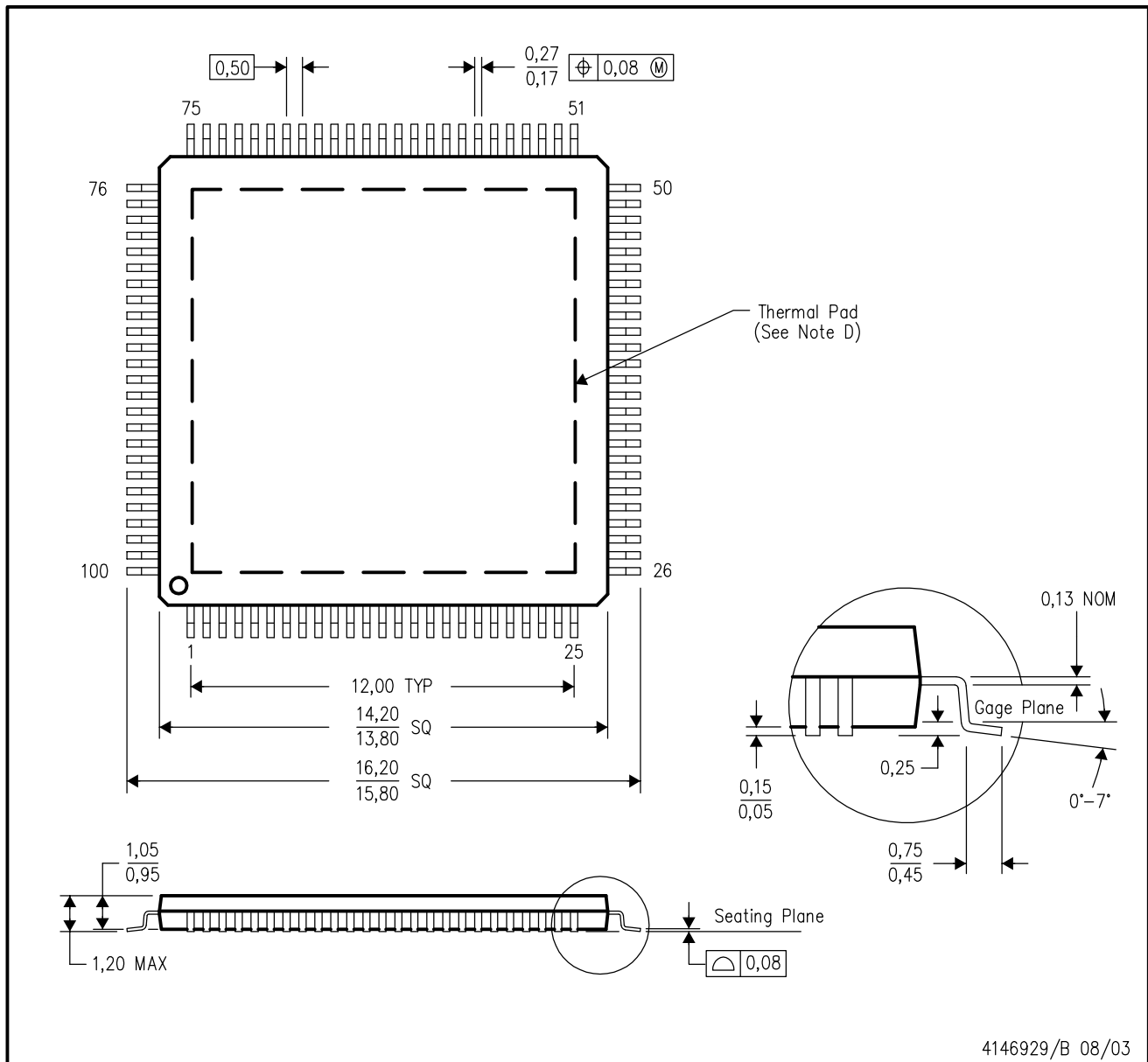

- NOTES:
- A. All linear dimensions are in millimeters.
  - B. This drawing is subject to change without notice.
  - C. Body dimensions do not include mold flash or protrusion
  - D. This package is designed to be molded to a thermal pad on the board. Refer to Technical Brief, PowerPad Thermally Enhanced Package, Texas Instruments Literature No. SLMA002 for information regarding recommended board layout. This document is available at [www.ti.com](http://www.ti.com) <<http://www.ti.com>>.
  - E. Falls within JEDEC MS-026

PowerPAD is a trademark of Texas Instruments.

**THERMAL INFORMATION**

This PowerPAD™ package incorporates an exposed thermal pad that is designed to be attached to a printed circuit board (PCB). The thermal pad must be soldered directly to the PCB. After soldering, the PCB can be used as a heatsink. In addition, through the use of thermal vias, the thermal pad can be attached directly to the appropriate copper plane shown in the electrical schematic for the device, or alternatively, can be attached to a special heatsink structure designed into the PCB. This design optimizes the heat transfer from the integrated circuit (IC).

For additional information on the PowerPAD package and how to take advantage of its heat dissipating abilities, refer to Technical Brief, PowerPAD Thermally Enhanced Package, Texas Instruments Literature No. SLMA002 and Application Brief, PowerPAD Made Easy, Texas Instruments Literature No. SLMA004. Both documents are available at www.ti.com.

The exposed thermal pad dimensions for this package are shown in the following illustration.

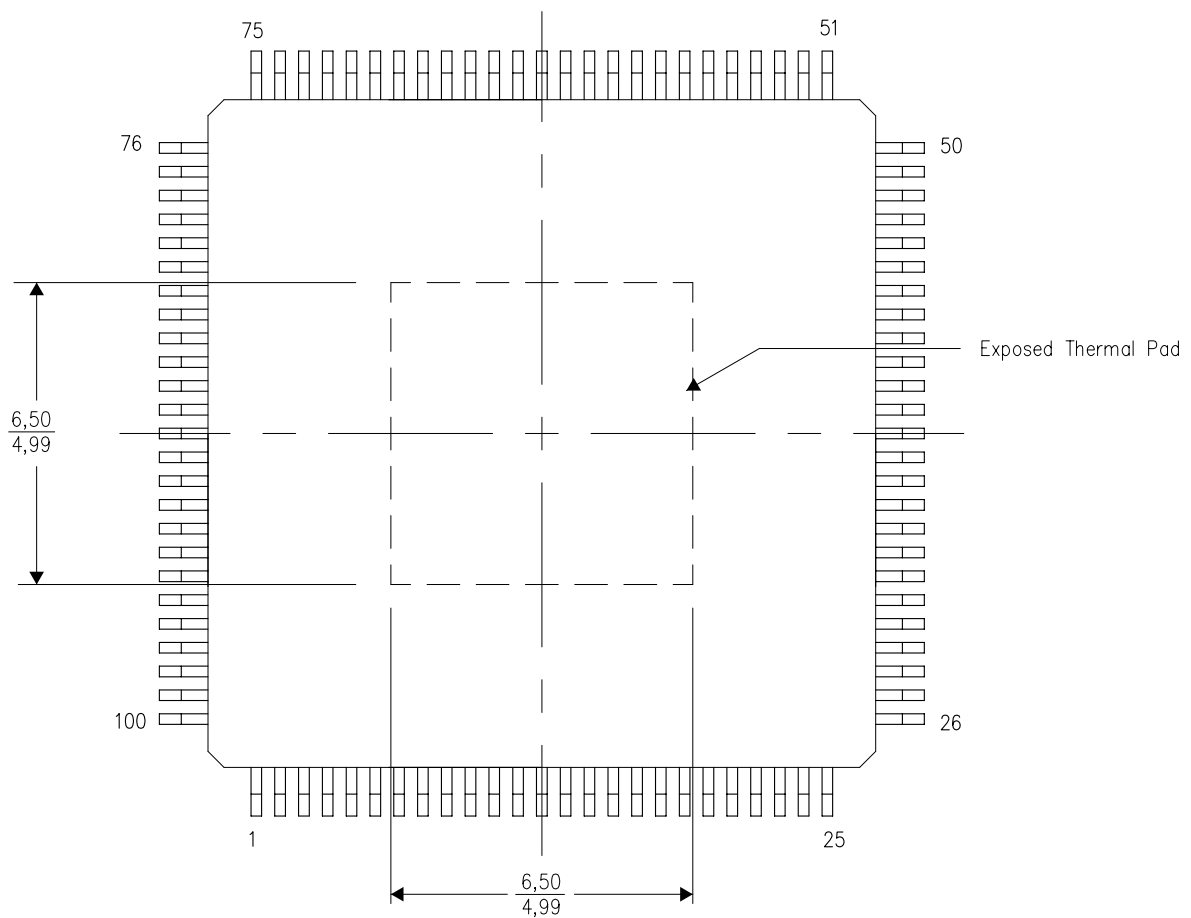

Top View

NOTE: All linear dimensions are in millimeters

Exposed Thermal Pad Dimensions

## PZP (S-PQFP-G100) PowerPAD™

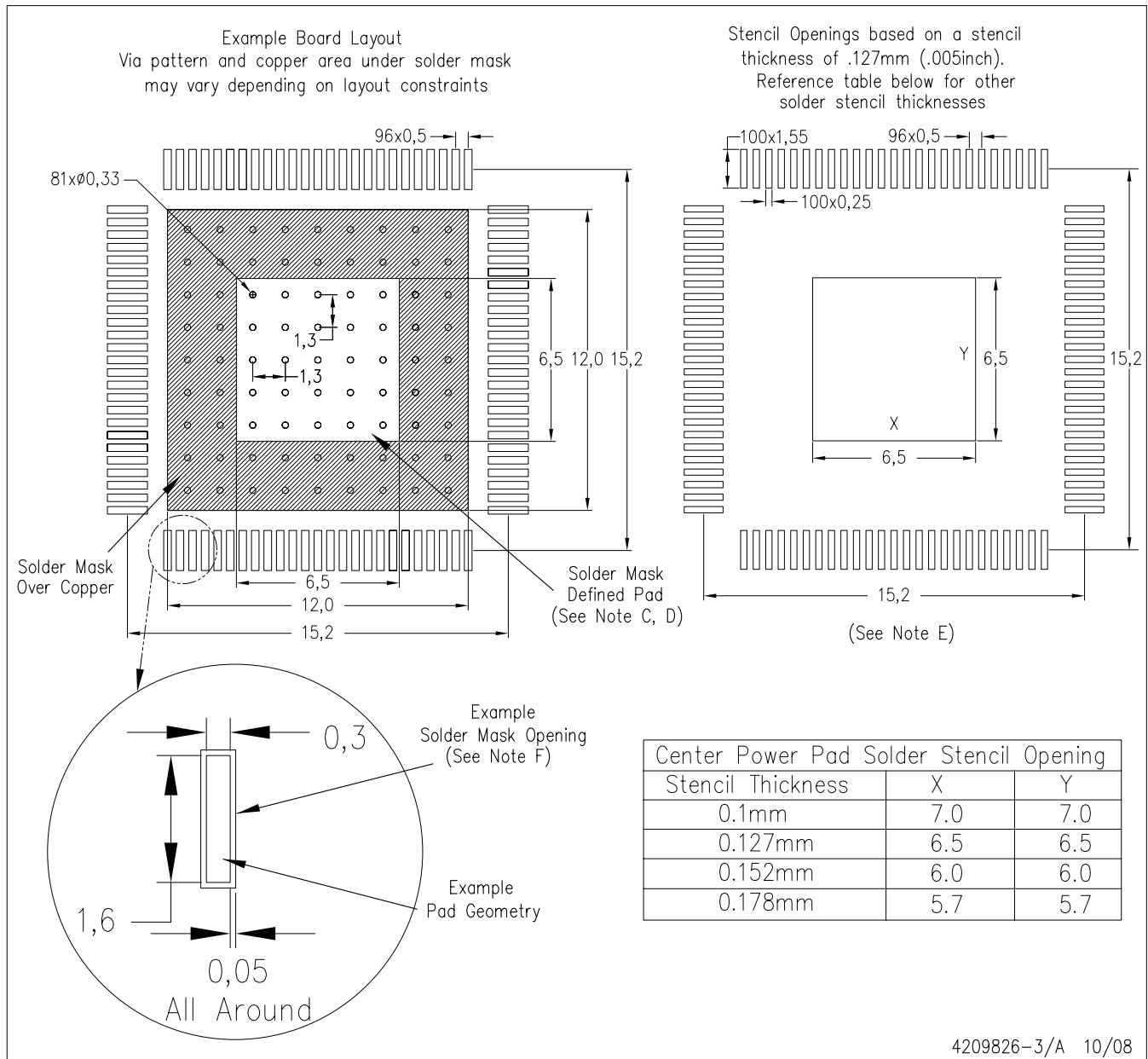

- NOTES:
- All linear dimensions are in millimeters.
  - This drawing is subject to change without notice.
  - Customers should place a note on the circuit board fabrication drawing not to alter the center solder mask defined pad.
  - This package is designed to be soldered to a thermal pad on the board. Refer to Technical Brief, PowerPAD Thermally Enhanced Package, Texas Instruments Literature No. SLMA002, SLMA004, and also the Product Data Sheets for specific thermal information, via requirements, and recommended board layout. These documents are available at [www.ti.com](http://www.ti.com) <<http://www.ti.com>>. Publication IPC-7351 is recommended for alternate designs.
  - Laser cutting apertures with trapezoidal walls and also rounding corners will offer better paste release. Customers should contact their board assembly site for stencil design recommendations. Example stencil design based on a 50% volumetric metal load solder paste. Refer to IPC-7525 for other stencil recommendations.
  - Customers should contact their board fabrication site for solder mask tolerances between and around signal pads.

PowerPAD is a trademark of Texas Instruments.

## IMPORTANT NOTICE

Texas Instruments Incorporated and its subsidiaries (TI) reserve the right to make corrections, modifications, enhancements, improvements, and other changes to its products and services at any time and to discontinue any product or service without notice. Customers should obtain the latest relevant information before placing orders and should verify that such information is current and complete. All products are sold subject to TI's terms and conditions of sale supplied at the time of order acknowledgment.

TI warrants performance of its hardware products to the specifications applicable at the time of sale in accordance with TI's standard warranty. Testing and other quality control techniques are used to the extent TI deems necessary to support this warranty. Except where mandated by government requirements, testing of all parameters of each product is not necessarily performed.

TI assumes no liability for applications assistance or customer product design. Customers are responsible for their products and applications using TI components. To minimize the risks associated with customer products and applications, customers should provide adequate design and operating safeguards.

TI does not warrant or represent that any license, either express or implied, is granted under any TI patent right, copyright, mask work right, or other TI intellectual property right relating to any combination, machine, or process in which TI products or services are used. Information published by TI regarding third-party products or services does not constitute a license from TI to use such products or services or a warranty or endorsement thereof. Use of such information may require a license from a third party under the patents or other intellectual property of the third party, or a license from TI under the patents or other intellectual property of TI.

Reproduction of TI information in TI data books or data sheets is permissible only if reproduction is without alteration and is accompanied by all associated warranties, conditions, limitations, and notices. Reproduction of this information with alteration is an unfair and deceptive business practice. TI is not responsible or liable for such altered documentation. Information of third parties may be subject to additional restrictions.

Resale of TI products or services with statements different from or beyond the parameters stated by TI for that product or service voids all express and any implied warranties for the associated TI product or service and is an unfair and deceptive business practice. TI is not responsible or liable for any such statements.

TI products are not authorized for use in safety-critical applications (such as life support) where a failure of the TI product would reasonably be expected to cause severe personal injury or death, unless officers of the parties have executed an agreement specifically governing such use. Buyers represent that they have all necessary expertise in the safety and regulatory ramifications of their applications, and acknowledge and agree that they are solely responsible for all legal, regulatory and safety-related requirements concerning their products and any use of TI products in such safety-critical applications, notwithstanding any applications-related information or support that may be provided by TI. Further, Buyers must fully indemnify TI and its representatives against any damages arising out of the use of TI products in such safety-critical applications.

TI products are neither designed nor intended for use in military/aerospace applications or environments unless the TI products are specifically designated by TI as military-grade or "enhanced plastic." Only products designated by TI as military-grade meet military specifications. Buyers acknowledge and agree that any such use of TI products which TI has not designated as military-grade is solely at the Buyer's risk, and that they are solely responsible for compliance with all legal and regulatory requirements in connection with such use.

TI products are neither designed nor intended for use in automotive applications or environments unless the specific TI products are designated by TI as compliant with ISO/TS 16949 requirements. Buyers acknowledge and agree that, if they use any non-designated products in automotive applications, TI will not be responsible for any failure to meet such requirements.

Following are URLs where you can obtain information on other Texas Instruments products and application solutions:

### Products

Amplifiers	<a href="http://amplifier.ti.com">amplifier.ti.com</a>
Data Converters	<a href="http://dataconverter.ti.com">dataconverter.ti.com</a>
DSP	<a href="http://dsp.ti.com">dsp.ti.com</a>
Clocks and Timers	<a href="http://www.ti.com/clocks">www.ti.com/clocks</a>
Interface	<a href="http://interface.ti.com">interface.ti.com</a>
Logic	<a href="http://logic.ti.com">logic.ti.com</a>
Power Mgmt	<a href="http://power.ti.com">power.ti.com</a>
Microcontrollers	<a href="http://microcontroller.ti.com">microcontroller.ti.com</a>
RFID	<a href="http://www.ti-rfid.com">www.ti-rfid.com</a>
RF/IF and ZigBee® Solutions	<a href="http://www.ti.com/lprf">www.ti.com/lprf</a>

### Applications

Audio	<a href="http://www.ti.com/audio">www.ti.com/audio</a>
Automotive	<a href="http://www.ti.com/automotive">www.ti.com/automotive</a>
Broadband	<a href="http://www.ti.com/broadband">www.ti.com/broadband</a>
Digital Control	<a href="http://www.ti.com/digitalcontrol">www.ti.com/digitalcontrol</a>
Medical	<a href="http://www.ti.com/medical">www.ti.com/medical</a>
Military	<a href="http://www.ti.com/military">www.ti.com/military</a>
Optical Networking	<a href="http://www.ti.com/opticalnetwork">www.ti.com/opticalnetwork</a>
Security	<a href="http://www.ti.com/security">www.ti.com/security</a>
Telephony	<a href="http://www.ti.com/telephony">www.ti.com/telephony</a>
Video & Imaging	<a href="http://www.ti.com/video">www.ti.com/video</a>
Wireless	<a href="http://www.ti.com/wireless">www.ti.com/wireless</a>

Mailing Address: Texas Instruments, Post Office Box 655303, Dallas, Texas 75265  
Copyright © 2008, Texas Instruments Incorporated